

PARTS FOR :
HYDRAULIC PRESS 10TONNE FLOOR TYPE
 MODEL : YK10F.V2

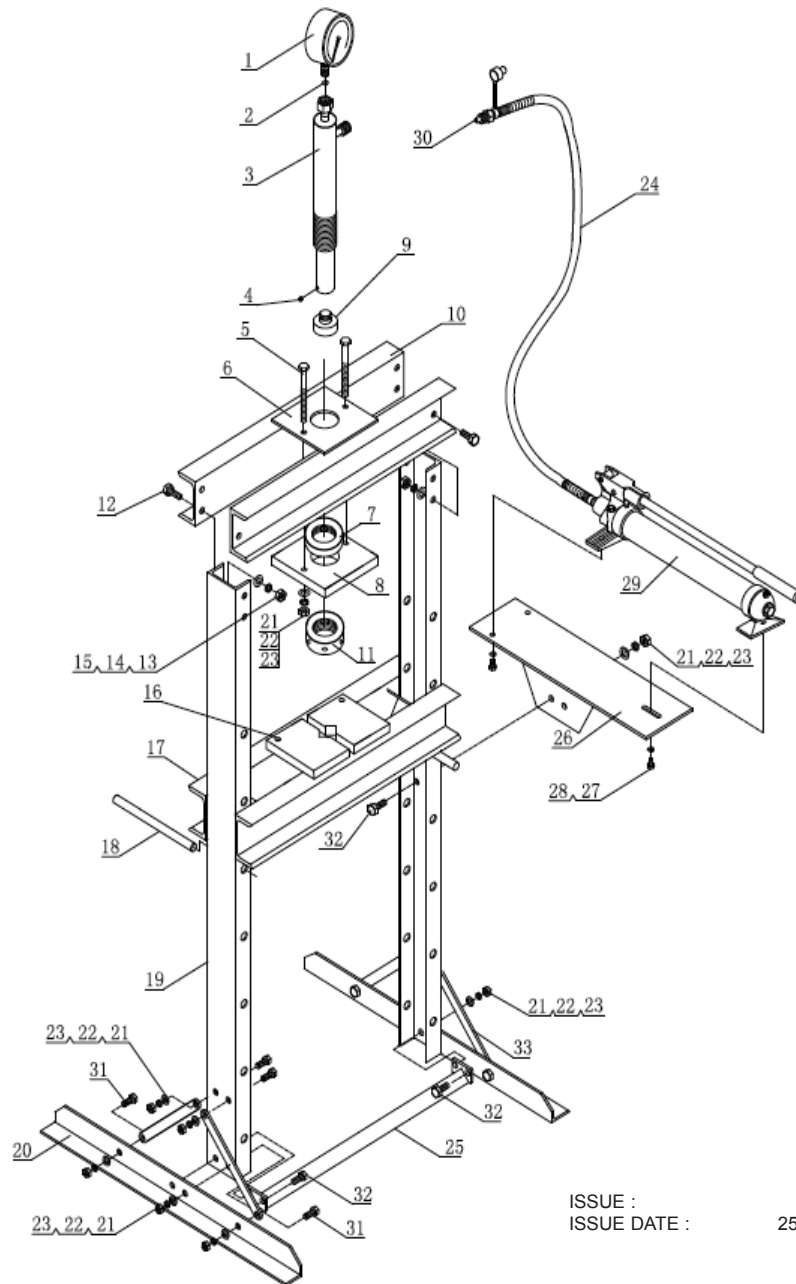

ISSUE : 1
 ISSUE DATE : 25/06/13

ITEM	PART NO	DESCRIPTION	ITEM	PART NO	DESCRIPTION
1	YK10F.V2-01	PRESSURE GAUGE	18	YK10F.V2-18	SUPPORT PIN
2	YK10F.V2-02	O-RING	19	YK10F.V2-19	UPRIGHT
3	YK10F.V2-03	RAM	20	YK10F.V2-20	BASE SUPPORT
4	YK10F.V2-04	SET SCREW	21	YK10F.V2-21	WASHER
5	YK10F.V2-05	BOLT	22	YK10F.V2-22	SPRING WASHER
6	YK10F.V2-06	SUPPORT PLATE	23	YK10F.V2-23	NUT
7	YK10F.V2-07	RING NUT	24	YK10F.V2-24	PUMP ASSEMBLY HOSE
8	YK10F.V2-08	RAM SUPPORT	25	YK10F.V2-25	UNION SUPPORT
9	YK10F.V2-09	SERRATED SADDLE	26	YK10F.V2-26	PUMP SUPPORT
10	YK10F.V2-10	UPPER FRAME	27	YK10F.V2-27	WASHER
11	YK10F.V2-11	ADAPTOR	28	YK10F.V2-28	BOLT
12	YK10F.V2-12	BOLT	29	YK10F.V2-29	PUMP ASSEMBLY
13	YK10F.V2-13	WASHER	30	YK10F.V2-30	COUPLING
14	YK10F.V2-14	SPRING WASHER	31	YK10F.V2-31	BOLT
15	YK10F.V2-15	NUT	32	YK10F.V2-32	BOLT
16	YK10F.V2-16	ARBOR PLATE	33	YK10F.V2-33	SUPPORT BRACE
17	YK10F.V2-17	TABLE			

NOTE: It is our policy to continually improve products and as such we reserve the right to alter data, specifications and component parts without prior notice.

IMPORTANT: No liability is accepted for incorrect use of product.

WARRANTY: Guarantee is 12 months from purchase date, proof of which will be required for any claim.

INFORMATION: For a copy of our latest catalogue and promotions call us on 01284 757525 and leave your full name and address, including postcode.