

FORD CVH ENGINES

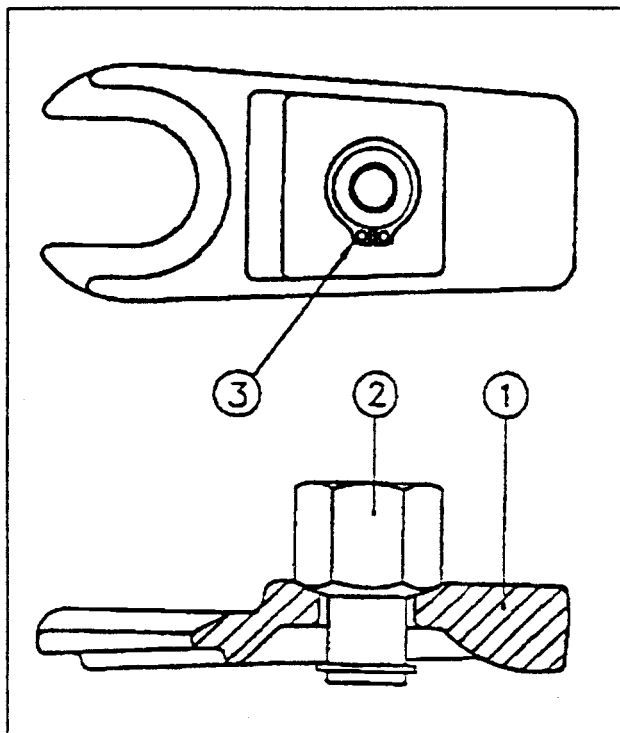

STANDARD PARTS LIST

1. VS150/1 Compressor Claw
2. VS150/2 Retained Nut
3. VS150/3 Circlip

Applications

FORD: CVH Engines - Fiesta 1.4, Orion , Escort 1.4 and 1.6 , including XR3i and RS Turbo Models.

Introduction

This tool provides a simple means for replacement of valve stem oil seals, damaged or broken valve springs without having to remove the cylinder head.

Warning

Be careful when compressing/decompressing springs as they can fly off cause injury or become lost.

Do not allow dirt or foreign matter to enter the engine parts.

Do not use air tools.

Instructions

Disconnect the battery earth lead.

Remove air cleaner unit, cam belt cover, rocker box cover and spark plugs in accordance with the manufacturers instructions.

Rotate the engine to bring the relevant piston to top dead centre, then remove the relevant rocker arm and hydraulic tappet.

Fit the valve spring compressor claw over the valve spring retaining washer and screw the spherical seating nut onto the M8 rocker stud until the heel of the compressor rests on the empty tappet hole Fig. 1.

Tighten the 22mm A/F nut to compress the valve spring and retainer just enough to allow the split collet to be released from the groove in the top of the valve stem.

Remove the collet then slowly release and remove the compressor tool, valve spring, and retaining washer.

Use suitable screwdriver to prise free the oil seal from stem guide.

Fit a new oil seal, and reassemble in reverse order.

Fig 1.

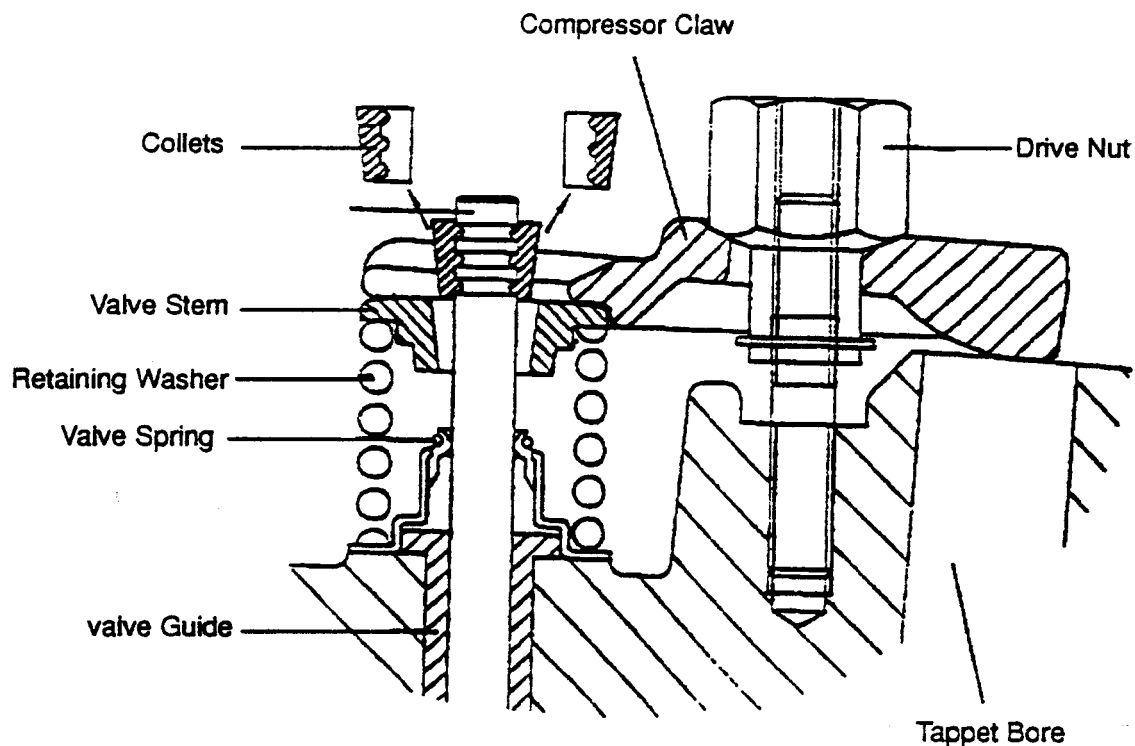

SEALEY *Professional*
TOOLS
AUTO SERVICE LINE



(01284) 757500



(01284) 767626

Original Date:- 210397
Issue Date:- 210397
Version Nbr:- 0
Date Modified:- N/A