

INSTRUCTIONS FOR:
**AIR RECIRCULATING ECONOMY
 SAND BLASTING KIT**
 Model: **SG10E**

Thank you for purchasing a Sealey product. Manufactured to a high standard this product will, if used according to these instructions and properly maintained, give you years of trouble free performance.

IMPORTANT: PLEASE READ THESE INSTRUCTIONS CAREFULLY. NOTE THE SAFE OPERATIONAL REQUIREMENTS, WARNINGS AND CAUTIONS. USE THIS PRODUCT CORRECTLY AND WITH CARE FOR THE PURPOSE FOR WHICH IT IS INTENDED. FAILURE TO DO SO MAY CAUSE DAMAGE AND/OR PERSONAL INJURY AND WILL INVALIDATE THE WARRANTY. PLEASE KEEP INSTRUCTIONS SAFE FOR FUTURE USE.

1. SAFETY INSTRUCTIONS

- ❑ **WARNING!** Turn off, or disconnect from air supply before servicing or performing any maintenance *and when unit is not in use.*
- ❑ **WARNING!** This shot blasting kit will generate gritty dust which could damage surface finishes and contaminate moving parts. It is recommended that shot blasting be carried out in a dedicated room free from unrelated materials, and where there is adequate lighting. Where this is not possible consideration should be given to covering exposed surfaces and masking moving parts as necessary.
- ❑ **WARNING!** Wear approved ear, eye, hand and respiratory protection when operating the blaster. A full range of personal safety equipment is available from your Sealey dealer.
- ✓ Maintain correct balance and ensure firm footing by wearing non-slip shoes.
- ✓ Spillages of abrasive material, which may be slippery, must be cleaned up immediately to avoid injury.
- ✓ Maintain the blaster in good condition (use an authorised service agent).
- ✓ Replace or repair damaged parts. Use recommended parts only. Unauthorised parts may be dangerous and will invalidate the warranty.
- ✓ Keep the unit clean for best and safest performance.
- ✓ Remove ill fitting clothing. Remove ties, watches, rings, and other loose jewellery, and contain long hair.
- ✓ Always keep the blast nozzle directed at the workpiece.
- ✓ If a failure or malfunction occurs **immediately disconnect from air supply.**
- ✓ Keep all other persons away from the working area. Contact with high pressure blast or inhaling the dust generated is dangerous. If other personnel are required in the vicinity of the shot blasting then they must wear protective equipment similar to the operator's.
- x **DO NOT** use the blaster for any purpose other than that for which it is designed.
- x **DO NOT** attempt to clear a blocked nozzle while the unit is pressurised.
- x **DO NOT** allow untrained persons to operate the blaster.
- x **DO NOT** leave the blaster operating unattended.
- x **DO NOT** stand on the blaster.
- x **DO NOT** direct air from the air hose at yourself or others.
- x **DO NOT** operate system with air supply exceeding 120 psi.
- x **DO NOT** operate the blaster if any parts are missing or damaged as this may cause failure and/or personal injury.
- x **DO NOT** get the blaster wet or use in damp or wet locations or areas where there is condensation.
- x **DO NOT** operate the blaster when you are tired or under the influence of alcohol, drugs or intoxicating medication.
- x **DO NOT** use any abrasive which contains free silica, as indicated in the Health & Safety Guidance Note EH59 (available from HMSO).



2. INTRODUCTION & SPECIFICATION

- 2.1. **Introduction**
 The SG10E sand blasting gun is suitable for use in the body shop. The feathering action makes this blaster ideal for treating stone chips. Supplied with a set of rubber nozzles for sealing the gun head to the panel and a 700g bottle of blasting grit. Spare nozzles are also available.
- 2.2. **Specification**
Model No.SG10E
Air Pressure.....60 to 120psi
Air consumption.....5 to 10cfm
- 2.3. **Abrasives**
 We recommend the use of Sealey Blasting Grit, part nos. **B/25KG** (25kg bag) or **SG10/SAND6** (6 X 700g containers).

3. AIR SUPPLY

- ❑ **WARNING!** Ensure the air supply does not exceed 120psi while operating the unit. Too high an air pressure will shorten the life of the unit due to excessive wear and may cause damage and/or personal injury.
- 3.1. Ensure the gun trigger is in the 'Off' position before connecting to the air supply.
- 3.2. Where possible the compressor should be sited in a separate room with the connecting airline kept as short as possible.
 The compressor should have an air filter and water separator (fig.1).
- 3.3. Drain the compressor air tank daily. Water in the air line will damage the unit.
- 3.4. The recommended hook-up procedure is shown in fig.1.
- 3.5. The minimum hose diameter should be 1/4" I.D. and fittings must have the same inside dimensions.
- 3.6. Keep hoses away from heat, oil and sharp edges. Check hoses for wear and ensure that all connections are secure.

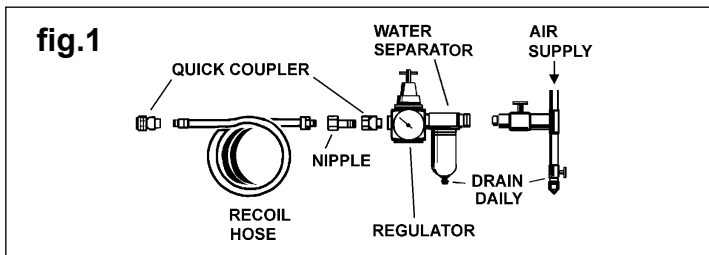

4. OPERATION

- WARNING! Ensure that you read, understand and apply the safety instructions in Section 1 before use.**
- WARNING! Wear approved ear, eye, hand and respiratory protection when operating the blaster.**
- 4.1 Attach an airline to the gun which has a 1/4" BSP fitting.
- 4.2 Remove the grit container from the gun by twisting it anticlockwise until it stops, then pull it off the head. Fill the container with the grit supplied. Align the three pins in the neck of the container with the corresponding gaps in the head flange and push the container onto the head. Twist the container clockwise to seal it to the head.
- 4.3 Ensure that the recycling bag is empty and that it is retained in place properly.
- 4.4 Fit the nozzle most suited to the job to be undertaken and push it fully on to the mouth of the gun. The round nozzle is for blasting general bodywork stone chip damage. The slotted nozzles are for blasting damage to either an external edge or internal fold.
- 4.5 It is strongly advised that the action of the gun is tested first on some scrap material before proceeding to the actual workpiece.
- 4.6 Place the nozzle over the damaged area and apply medium pressure in order to seal the nozzle against the bodywork. (The recycling action will not work efficiently if the nozzle is not sealed to the body). Do not apply excessive pressure as this may cause the rubber nozzle to distort.
- 4.7 Partially depress the trigger to get a light feathering action on the damage. Remove the nozzle and inspect the area. Proceed as required. Fully depressing the trigger will give the strongest blasting action.
- 4.8 When work is complete, disconnect the gun from the air supply. Remove the main grit container and empty any unused grit back into a suitable container. Loosen the neck of the recirculation bag and remove it. The recirculated grit should be finely sieved to remove any other particles before returning it to a grit container.

5. MAINTENANCE

- WARNING! Disconnect from the air supply before performing any maintenance!**
- WARNING! Wear ear, eye, hand and respiratory protection when undertaking any maintenance.**
- 5.1. **Gun maintenance.** Keep all parts of the gun clean for best performance.
- 5.2. Do not leave recirculated grit in the bag. Always completely empty bag after each use.
- 5.3. Lubricate the plunger, between the trigger and the gun handle with a light grease.



6. PARTS

1	SG10E.01	POT
2	SG10E.02	POT COVER
3	SG10E.03	AIR INLET CONNECTION
4	SG10E.04	GUN BODY
5	SG10E.05	SPRING
6	SG10E.06	O-RING
7	SG10E.07	O-RING
8	SG10E.08	AIR VALVE BODY
9	SG10E.09	O-RING
10	SG10E.10	WASHER
11	SG10E.11	KNOB
12	SG10E.12	NOZZLE
13A	SG10E.13A	NOZZLE "A"
13B	SG10E.13B	NOZZLE "B"
13C	SG10E.13C	NOZZLE "C"
13D	SG10E.13D	NOZZLE "D"
14	SG10E.14	NOZZLE JOINT
15	SG10E.15	NUT
16	SG10E.16	NOZZLE
17	SG10E.17	TRIGGER PIN
18	SG10E.18	TRIGGER
19	SG10E.19	POT
20	SG10E.20	SAND RETURN BAG
--	SG10/SAND6	GRIT - 6 x 700g CONTAINERS
--	B/25KG	GRIT - 25KG BAG

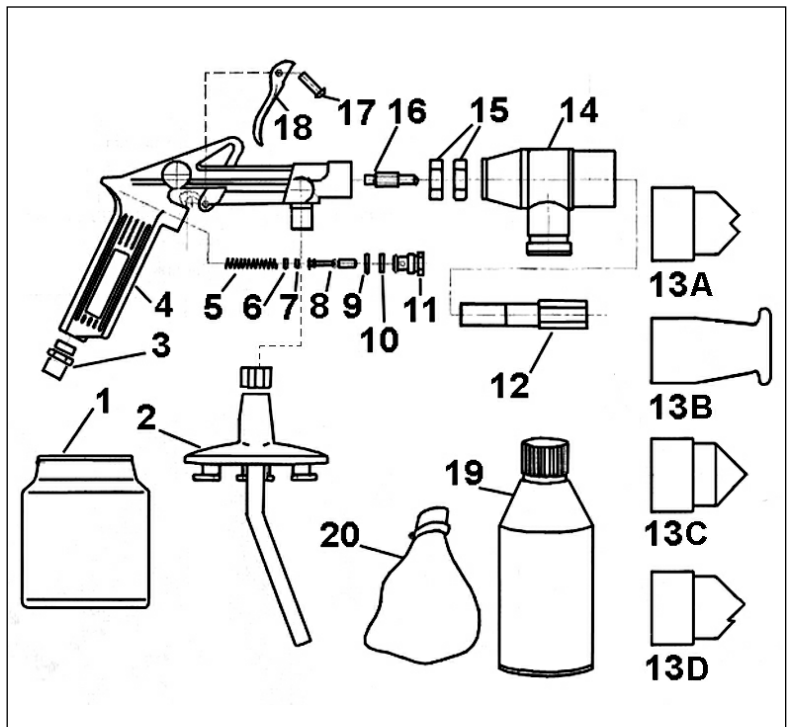

Declaration of Conformity We, the sole importer into the UK, declare that the product listed here is in conformity with the following standards and directives.

**ECONOMY RECIRCULATING SAND
BLASTING GUN**
MODEL NO: SG10E
97/23/EC Pressure Equipment Directive
93/68/EEC Marking Directive



The construction file for this product is held by the Manufacturer and may be inspected, by a national authority, upon request to Jack Sealey Ltd.

Signed by Steve Buckle

Date 26th September 2006

For Jack Sealey Ltd. Sole importer into the UK of Sealey Power Products.

NOTE: It is our policy to continually improve products and as such we reserve the right to alter data, specifications and component parts without prior notice.

IMPORTANT: No responsibility is accepted for the incorrect use of this product.

WARRANTY: Guarantee is 12 months from purchase date, proof of which will be required for any claim.

INFORMATION: For a copy of our latest catalogue and promotions call us on 01284 757525 and leave your name and address, including postcode.



Sole UK Distributor
Sealey Group,
Bury St. Edmunds, Suffolk.



01284 757500



01284 703534



www.sealey.co.uk



sales@sealey.co.uk