

Thank you for purchasing a Sealey Product. Manufactured to a high standard this product will, if used according to these instructions and properly maintained, give you years of trouble free performance.

IMPORTANT: PLEASE READ THESE INSTRUCTIONS CAREFULLY. NOTE THE SAFE OPERATIONAL REQUIREMENTS, WARNINGS AND CAUTIONS. USE THIS PRODUCT CORRECTLY AND WITH CARE FOR THE PURPOSE FOR WHICH IT IS INTENDED. FAILURE TO DO SO MAY CAUSE DAMAGE AND/OR PERSONAL INJURY AND WILL INVALIDATE THE WARRANTY. PLEASE KEEP INSTRUCTIONS SAFE FOR FUTURE USE.

1. SAFETY INSTRUCTIONS

- ✓ Follow all workshop Health & Safety rules, regulations and conditions when using tool.
- WARNING!** Disconnect from air supply before changing grinding bit or servicing.
- ✓ Maintain die grinder in good condition and replace any damaged or worn parts. Use genuine parts only. Unauthorised parts may be dangerous and will invalidate the warranty.
- WARNING!** Check correct air pressure is maintained and not exceeded. We recommend 90psi.
- ✓ Keep air hose away from heat, oil and sharp edges. Check air hose for wear before each use and ensure that all connections are secure.
- WARNING!** Before each use check grinding bit is secure, and the bit is not worn or damaged. If damaged, replace immediately.
- ✓ Ensure replacement grinding bits are not damaged (cracks, deformations or splinters etc).
- ✓ Always use a grinding bit suitable for the material being ground. Ensure the maximum speed specification of the bit is higher than that indicated on the machine data plate.
- WARNING!** Always wear approved eye or face protection when operating the die grinder.
- ✓ Use breathing protection in accordance with COSHH regulations if fumes or dust pose a hazard.
- ✓ Wear ear defenders and safety gloves.
- ✓ Keep hands and body clear of the workpiece when operating the die grinder.
- ✓ Maintain correct balance and footing. Ensure the floor is not slippery and wear non-slip shoes.
- ✓ Secure unstable workpiece with a clamp, vice or other adequate holding device.
- ✓ Keep children and non essential persons away from the work area.
- ✓ Avoid subjecting grinding bit to excessive strain, always ease grinding bit against workpiece (a harsh impact may break the bit). Maintain a controlled progression.
- ✗ DO NOT hold the workpiece by hand. Use clamps or a vice to secure the workpiece.
- ✗ DO NOT use the die grinder for a task it is not designed to perform.
- WARNING!** DO NOT use die grinder if damaged or faulty. Contact your local service agent.
- ✗ DO NOT use die grinder unless you have been instructed in its use by a qualified person.
- ✗ DO NOT carry the die grinder by the air hose, or yank the hose from the air supply.
- ✗ DO NOT direct air from the air hose at yourself or others.
- WARNING!** DO NOT grind any materials containing asbestos.
- ✗ DO NOT turn the die grinder on whilst the grinding bit is in contact with the workpiece.
- ✗ DO NOT use die grinder where there are flammable liquids, solids or gases such as paint solvents, including waste wiping or cleaning rags etc. as generated sparks may be dangerous.
- ✗ DO NOT touch the workpiece close to the ground surface as it will be very hot. Allow to cool. The workpiece may also be very sharp.
- ✗ DO NOT operate die grinder if you are tired or under the influence of alcohol, drugs or intoxicating medication.
- ✓ When not in use disconnect from air supply and store in a safe, dry, childproof location.

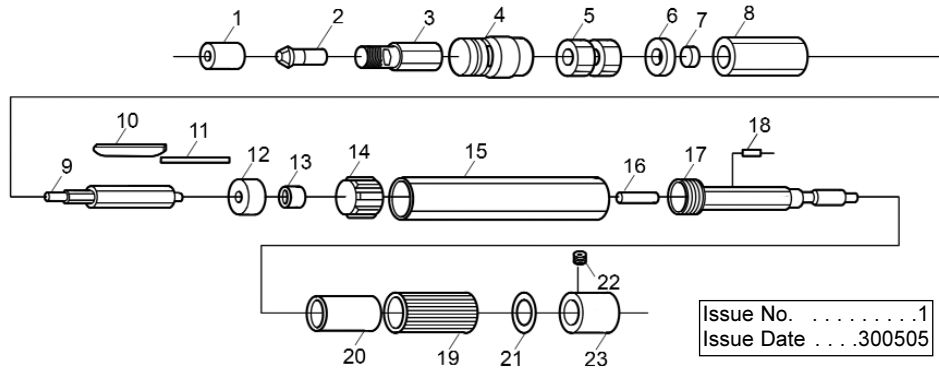

| ITEM | PART NO. | DESCRIPTION | ITEM | PART NO. | DESCRIPTION |
|------|----------|---------------|------|----------|-----------------|
| 01. | SA673.01 | CLAMPING NUT | 13. | SA673.13 | BALL BEARING |
| 02. | SA673.02 | COLLET | 14. | SA673.14 | INTAKE PLATE |
| 03. | SA673.03 | FRONT COVER | 15. | SA673.15 | SLEEVE |
| 04. | SA673.04 | COLLET BASE | 16. | SA673.16 | INTAKE TUBE |
| 05. | SA673.05 | BALL BEARING | 17. | SA673.17 | HOSE PLUG |
| 06. | SA673.06 | SPACER | 18. | SA673.18 | PIN |
| 07. | SA673.07 | LATERAL DISC | 19. | SA673.19 | SLIDING RING |
| 08. | SA673.08 | CYLINDER | 20. | SA673.20 | O-RING |
| 09. | SA673.09 | ROTOR | 21. | SA673.21 | O-RING |
| 10. | SA673.10 | ROTOR BLADE | 22. | SA673.22 | SCREW |
| 11. | SA673.11 | PIN | 23. | SA673.23 | REAR END HOLDER |
| 12. | SA673.12 | BEARING PLATE | | | |

Declaration of Conformity



We, the sole importer into the UK, declare that the product listed here is in conformity with the following standards and directives. The construction file for this product is held by the Manufacturer and may be inspected, by a national authority, upon request to Jack Sealey Ltd.

Micro Air Die Grinder Models: SA673

98/37/EC Machinery Directive
 93/68/EEC CE Marking Directive



Signed by Mark Sweetman

30th May 2005

For Jack Sealey Ltd. Sole importer into the UK of Sealey Power Tools.

NOTE: It is our policy to continually improve products and as such we reserve the right to alter data, specifications and component parts without prior notice. **IMPORTANT:** No liability is accepted for incorrect use of this equipment. **WARRANTY:** Guarantee is 12 months from purchase date, proof of which will be required for any claim. **INFORMATION:** For a copy of our latest catalogue and promotions call us on 01284 757525 and leave your full name and address, including postcode.

DANGER OF FIRE/EXPLOSION HAZARD

- WARNING!** The grinding process can produce streams of sparks which are a potential source of ignition, especially when grinding metal.
- DO NOT** use the grinder where there are flammable liquids, solids or gases.
- DO NOT** allow grinder sparks to make contact with the operator's clothing or any other fabric such as cleaning rags. Fabrics contaminated with inflammable materials such as petrol, oil, grease, paint and solvents are a particular fire hazard.
- To reduce the risk of clothing catching fire the operator should wear wool or cotton outer garments treated with a fire retardant in preference to man-made fibres.

Risk of Hand Arm Vibration Injury

Micro Air Die Grinder Model SA673 when operated in accordance with these instructions and tested in accordance with EN 28662-2: 1994 results in the following vibration emission declared in accordance with BS EN12096: 1996.

Measured vibration emission value:0.2m/s²

Uncertainty:0.1m/s²

These values are suitable for comparison with emission levels of other tools that have been subject to the same test.

This tool may cause hand-arm vibration syndrome if its use is inadequately managed.

Recommended Measures to reduce risk of hand-arm vibration syndrome:

This item represents a low Hand Arm Vibration risk to users. The calculated maximum usage period exceeds 8 hours. We recommend appropriate safety equipment is utilised and regular breaks for the operator are employed to reduce any residual risk of fatigue or repetitive strain injury.

2. INTRODUCTION & SPECIFICATION

Air motor with quality bearings for smooth and powerful operation. Shrouded exhaust gives quieter operation. Suitable for professional users. Supplied with spanners and grinding points, air tool oil, in-line oiler and quick connector.

Contents: Air Micro Grinder
.....10 Grinding Points
..... Air Tool Oil
..... In-line Oiler
..... Quick Connector
..... Chuck Spanner
Free Speed:58000rpm
Collet:Ø3mm (1/8")
Operating Pressure:90psi



3. PREPARING TOOL FOR USE

3.1 AIR SUPPLY

Recommended hook-up procedure is shown in fig 1.

- WARNING!** Ensure the air supply is clean and does not exceed 90psi while operating the die grinder. Too high an air pressure and unclean air will shorten the product life due to excessive wear, and may be dangerous causing damage and/or personal injury.

- 3.1.1 Ensure die grinder switch is in the "off" position before connecting to the air supply.
- 3.1.2 You will require an air pressure of 90psi.
- 3.1.3 Drain the compressors air tank daily. Water in the air line will damage the die grinder.
- 3.1.4 Clean the compressors air inlet filter weekly.
- 3.1.5 Line pressure should be increased to compensate for unusually long air hoses (over 8 metres). The minimum hose diameter should be 1/4" I.D. and fittings must have the same inside dimensions.
- 3.1.6 Keep hose away from heat, oil and sharp edges. Check hose for wear, and make certain that all connections are secure.

3.2 COUPLINGS

Vibration may cause failure if a quick change coupling is connected directly to the die grinder. To overcome this, connect a leader hose to the grinder. A quick change coupling may then be used to connect the leader hose to the air line recoil hose. See figs 1 & 2.

fig 1

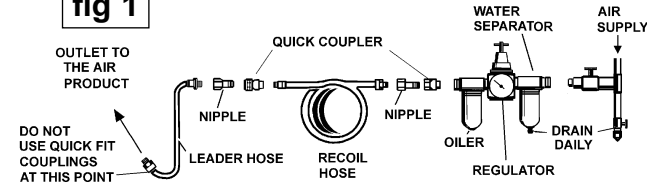
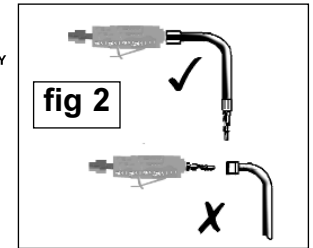

fig 2



4. OPERATING INSTRUCTIONS

4.1 OPERATING

- WARNING!** Ensure you read, understand and apply safety instructions.

- 4.1.1 Connect the die grinder to the air supply.
- 4.1.2 To start, hold firmly and twist the gripped section ("ON" and "OFF" are marked on the body).
- 4.1.3 The bit must be running at its maximum speed before attempting to grind the workpiece.
- 4.1.4 Slowly and smoothly bring the grinding stone toward the workpiece (avoid jerky movements).

Avoid subjecting stone to excessive strain or harsh impacts.

Always hold die grinder firmly and ease grinding stone against workpiece. Maintain a controlled progression.

4.2 CHANGING GRINDING STONES

- WARNING!** Disconnect from the air supply before changing grinding stone.

- 4.2.1 Check that grinding stones are not damaged in any way such as cracks, deformations or splinters etc. Damaged stones must not be used.
 - 4.2.2 Use wrenches provided to loosen collet locking collar. Insert grinding bit and re-lock collar.
- DO NOT** allow die grinder to free run for an extended period of time as this will shorten bearing life.

5. MAINTENANCE

- WARNING!** Disconnect die grinder from air supply before changing accessories, servicing or performing maintenance. Replace or repair damaged parts. *Use genuine parts only. Unauthorised parts may be dangerous and will invalidate the warranty.*

- 5.1 If air supply does not have an oiler, lubricate the air tool daily with a few drops of Sealey air tool oil dripped into the air inlet to prolong its life.
- 5.2 Clean the die grinder after use.
- 5.3 Loss of power or erratic action may be due to the following:
 - a) Excessive drain on the air line. Moisture or restriction in the air pipe. Incorrect size or type of hose connectors. To remedy check the air supply and follow instructions in chapter 3.
 - b) Grit or gum deposits in the die grinder may also reduce performance. If your model has an air strainer (located in the area of the air inlet), remove the strainer and clean it. Flush the die grinder out with gum solvent oil or an equal mixture of SAE No 10 oil and paraffin. Allow to dry before use.
- 5.4 For a full service contact your local Sealey service agent.
- 5.5 When not in use, disconnect from air supply, clean die grinder and store in a safe, dry, childproof location.