

## INSTRUCTIONS FOR: OPEN & SHORT DC CIRCUIT TESTER MODEL:FF400

Thank you for purchasing a Sealey product. Manufactured to a high standard this product will, if used according to these instructions and properly maintained, give you years of trouble free performance.

### ⚠ IMPORTANT:

**PLEASE READ THESE INSTRUCTIONS CAREFULLY. NOTE THE SAFE OPERATIONAL REQUIREMENTS, WARNINGS & CAUTIONS. USE THE PRODUCT CORRECTLY AND WITH CARE FOR THE PURPOSE FOR WHICH IT IS INTENDED. FAILURE TO DO SO MAY CAUSE DAMAGE AND/OR PERSONAL INJURY AND WILL INVALIDATE THE WARRANTY. PLEASE KEEP THESE INSTRUCTIONS SAFE FOR FUTURE USE.**

### SAFETY INSTRUCTIONS

1. Only for use on DC voltage, don't connect to circuit exceeding 42 volts DC under any circumstances.
2. Do not use on AC voltage.
3. Do not use on any circuit directly or indirectly connected to AC lines or any other AC power source.
4. Do not use with any component or circuits of the ignition system.
5. Before using this device, check the vehicle's electrical wiring

and disconnect any part or system sensitive to voltage and current pulses such as air bags, electronic control modules, etc.

6. After you finish checking vehicle, make sure you have correctly restored all the connections which you disconnected.
7. Always follow the instructions and procedures indicated in the vehicle's service manual before attempting to disconnect any part or subsystem of the electrical circuit.

Exceeding the limits listed above when using this apparatus, or not observing the precautions listed above can expose you to physical injury and permanently damage your instrument and parts and circuits of the vehicle under test.

### INTRODUCTION

This instrument is designed to identify and trace wires or cables without damaging the insulation. You can also use it in checking for short circuit and locating open circuit and so on. There are a Sender and a Receiver included in the instrument.

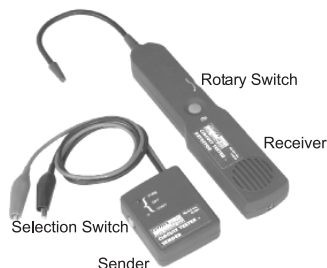

### HOW TO USE THE PROBE

The probe of the Receiver is built of coiled steel and may be bent as needed, in order to reach wires in congested or difficult areas. Depending on the circuit characteristic and sensitivity settings, the probe will pick up the signal from the wire in a range of positions. However, for the best possible range the Receiver's probe tip (black cap) should be positioned perpendicular (at 90°) to the wire being traced and either above or below it. See Figure.

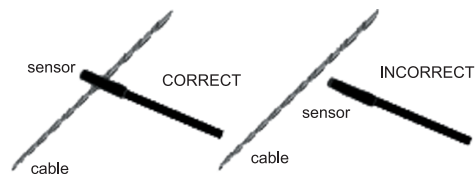

### SETTING SENSITIVITY LEVEL

To turn on Receiver or increase its sensitivity, turn the rotary switch of Receiver clockwise. To turn off Receiver or decrease its sensitivity, turn the rotary switch anticlockwise.

### WIRE TRACING

Note: Observe the limits and safety precautions at all times.

1. Set the switch of Sender to "TONE", the red LED of Sender lights. If the red LED doesn't light, please check the battery.
2. Switch Receiver on, set the rotary switch in middle position. Press and hold TEST button, meanwhile move the sensor close to the test lead of Sender. Receiver receives the signal

and give audio signal. If so, it means that the unit works correctly.

3. Connect the black test lead to the circuit's positive supply (or to the negative for vehicles with positive supply connected to chassis). Connect the red test lead to the wire to be traced. A fuse socket (in place of the blown fuse), connector, etc. is convenient place.
4. Set the rotary switch in middle position. Press and hold TEST button, meanwhile move the probe as close as possible to the wire to be traced. The Receiver's sensor should be positioned perpendicular (at 90°) to the wire being traced and either above or below it.
5. Receiver gives audio signal. Trace the wire by following the audio signal of Receiver. If you move the probe away from the wire, the audio signal will decrease and then disappears.
6. If it is difficult or impossible to get the Receiver to pick-up any signal, please increase the sensitivity and try again. For the suspectable place, check it twice. See Figure.
7. When you finish tracing, disconnect the test leads' connections, set the Sender's switch in OFF position. Loose TEST button.

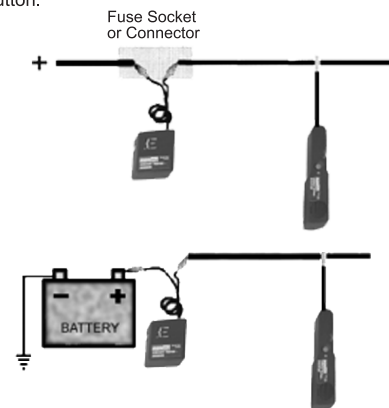

## CHECKING FOR SHORT CIRCUIT

Note: Observe the limits and safety precautions at all times.

1. Disconnect the power to the wire to be checked and remove all the loads from this wire (for example: remove the lamp from the wire).
2. Set the switch of Sender to "CONT" position. Connect the test leads to a couple of wires which are to be checked.
3. When the resistance is less than 10k ohm, the green LED of "CONT" will light. With all the loads having been removed, the green LED's lighting indicates that the couple of wires are in short circuit.

## LOCATING OPEN CIRCUIT

Note: Observe the limits and safety precautions at all times.

1. Set the switch of Sender to "TONE", the red LED of Sender lights. If the red LED doesn't light, please check the battery.
2. Switch the Receiver on, set the rotary switch in middle position. Press and hold TEST button, meanwhile move the sensor close to the test lead of Sender. The Receiver receives the signal and give audio signal. If so, it means that the unit works correctly.
3. Connect the black test lead to the circuit's positive supply (or to the negative for vehicles with positive supply connected to chassis). Connect the red test lead to the wire to be checked. A fuse socket (in place of the blown fuse), connector, etc. is convenient place.
4. Switch Receiver on and set its rotary switch in middle position. Press and hold "TEST" button and slowly sweep the wire with the probe, ensuring the probe is perpendicular and above or below the wire being checked and as close as possible to it.
5. Follow the wire or check it at different points, starting from the

- Sender and moving towards the load (accessory, light, etc) observing the positioning of the probe as indicated above.
6. Continue this procedure while the audio signal indicates the integrity of the circuit, If audio signal stops, it indicates that the probe has passed beyond the open, break or bad connection in the circuit. See Figure.
  7. If it is difficult or impossible to get the Receiver to pick-up any signal, please increase the sensitivity and try again.
  8. Double check by positioning the probe before and after the suspected place. If the open circuit point has been found, the audio indicator will show circuit integrity on the side, and not on other. At this point, where the audio signal stops, you have found the open circuit.
  9. When you finish locating, disconnect the test leads' connections, set the Sender's switch in OFF position. Loose TEST button.

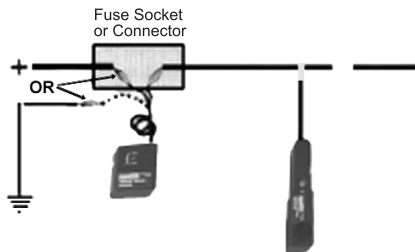

## WIRE IDENTIFICATION

Note: Observe the limits and safety precautions at all times.

1. Set the switch of Sender to "TONE", the red led of Sender lights. If the red LED doesn't light, please check the battery.
2. Switch the Receiver on, set the rotary switch in middle position. Press and hold TEST button, meanwhile move the sensor close to the test lead of Sender. The Receiver receives the

signal and give audio signal. If so, it means that the unit works correctly.

3. Connect the black test lead to the circuit's positive supply (or to the negative for vehicles with positive supply connected to chassis). Connect the red test lead to the wire to be identified. A fuse socket (in place of the blown fuse), connector, etc. is convenient place.
4. Sweep all the suspectable wires until the audio signal is at its maximum. the wire which makes Receiver give the loudest audio signal is the wire to be identified.  
In the case of tightly packed wires (bundles, conduit, etc.), it may be necessary to spread these apart to facilitate the identification process of a particular wire.
5. When you finish identification, disconnect the test leads' connections, set the Sender's switch in OFF position. Loose TEST button.

## MAINTENANCE

- ❑ **WARNING! DO NOT** attempt to repair or service your FF400 unless you are qualified to do so. To avoid damage to the FF400 do not get water inside the case.
- 4.1. Periodically wipe the case with a damp cloth and mild detergent. Do not use solvents.
  - 4.2. Turn the sender and receiver off when not in use and remove the batteries if stored for a long period of time.
  - 4.3. Do not store in a place of high humidity or high temperature.
  - 4.4 To replace the batteries on either the sender or the receiver, simply undo the Philips screw on the rear of the unit battery cover and replace the battery with a 9V (6F22).

### DISPOSAL OF THIS ARTICLE

Dear Customer,  
If you intend to dispose of this article, then please keep in mind that many of its components consist of valuable materials, which can be recycled.  
Please do not discharge it in the garbage bin, but check with your local council for recycling facilities in your area.



## DECLARATION OF CONFORMITY

**Declaration of Conformity** We, the sole UK importer, declare that the product listed below is in conformity with the following standards and directives.

### OPEN & SHORT DC CIRCUIT TESTER

Model: FF400

89/336/EEC EMC Directive  
93/68/EEC CE Marking Directive

**CE** The construction file for this product is held by the Manufacturer and may be inspected, by a national authority, upon request to Jack Sealey Ltd.  
Signed by Mark Sweetman

22nd July 2005

For Jack Sealey Ltd. Sole UK importer of Sealey Professional Tools.

**NOTE:** It is our policy to continually improve products and as such we reserve the right to alter data, specifications and component parts without prior notice.

**IMPORTANT:** No liability is accepted for incorrect use of this equipment.

**WARRANTY:** Guarantee is 12 months from purchase date, proof of which will be required for any claim.

**INFORMATION:** For a copy of our latest catalogue and promotions call us on **01284 757525** and leave your full name and address, including postcode.

**SEALEY TOOLS**  
AUTO SERVICE LINE

Sole UK Distributor

Sealey Group,

Bury St. Edmunds, Suffolk.

Web address: [www.sealey.co.uk](http://www.sealey.co.uk)

E-mail: [sales@sealey.co.uk](mailto:sales@sealey.co.uk)



01284 757500



01284 703534