

INSTRUCTIONS FOR:

HYDRAULIC BEARING SEPARATOR/PULLER SET

MODELS: **PS980.V2 PS985.V2**

1. INTRODUCTION

1.1. INTRODUCTION

PS980 has a cast puller yoke and a forged bearing separator. The separator covers bearing diameters from 90 to 105mm and the extension rods provide a maximum reach of 420mm. The 10 ton hydraulic ram is also compatible with sets PS981.V2 and PS982.V2. The PS985.V2 is similar to PS980.V2 except that the splitter covers bearings from 120 to 150mm diameter and ram extensions and a plug are included.

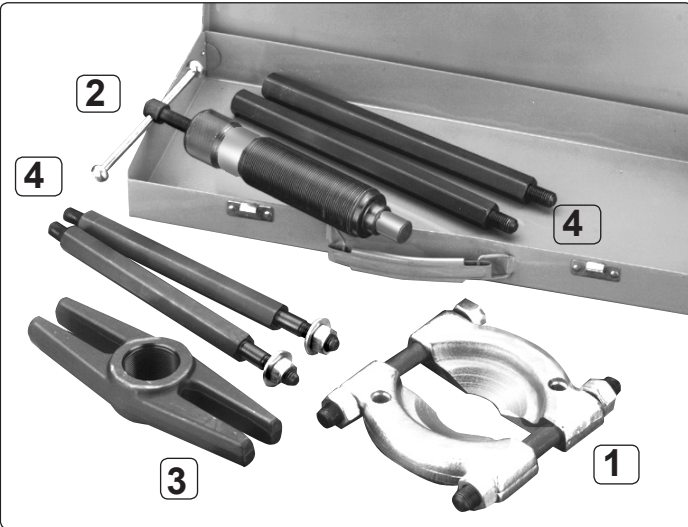

2. CONTENTS & PARTS

Model	Part No.	Description	PARTS LIST	Issue Date:-	12/05/05
1	PS988	Bearing Separator 90 to 105mm	Issue No.:-	3	
2	PS990	Hydraulic Ram, 10 ton			
3	PS982/9014	Beam			
4	PS982/9016	Rod, Main & Extension, 2 off each			
-	PS982/8013	Centre Adaptor (not shown)			
Model	Part No.	Description			
1	PS989	Bearing Separator 120 to 150mm			
2	PS990	Hydraulic Ram, 10 ton			
3	PS985/03	Beam			
4	PS985/04	Rod, Main & Extension, 2 off each			
-	PS985/05	Plug (not shown)			
-	PS982/8013	Centre Adaptor (not shown)			
-	PS982/8014	Ram Extension, 50mm (not shown)			
-	PS982/8015	Ram Extension, 100mm (not shown)			
	PS982.V2-RK	Repair Kit for PS990 Ram (not supplied)			
	PS982/OIL	15grm single refill of oil (Not shown, not supplied).			

3. SAFETY INSTRUCTIONS

- WARNING!** Ensure all Health and Safety, local authority, and general workshop practice regulations are strictly adhered to when using tools.
- DO NOT** use tools if damaged or worn.
- Maintain the tools in good and clean condition for best and safest performance.
- Ensure all threads are clean and well lubricated.
- Always check that puller is correctly assembled and is square with the workpiece.
- If vehicle is raised, ensure it is adequately supported with axle stands, ramps, etc. as appropriate.
- Wear suitable clothing to avoid snagging. Do not wear jewellery. Tie back long hair.
- Wear approved eye protection. A full range of personal safety equipment is available from your Sealey dealer.
- Where possible shield workpiece with canvas or similar to provide protection against failed parts.
- DO NOT** heat puller jaws when heating a gear or bearing as this will affect the temper and, therefore, the strength of the material.

- DO NOT** use any tool or lever to turn the ram tommy bar, use hand effort only.
 - DO NOT** hit workpiece, or ram, with a hammer if workpiece has not moved with maximum puller force applied. Use a larger capacity puller.
 - Account for all tools and parts being used and do not leave them in or on the vehicle.
- IMPORTANT:** Always refer to the vehicle manufacturer's service instructions, or proprietary manual, to establish the correct procedure and data. These instructions for use are provided as a guide only.

4. INSTRUCTIONS FOR USE

- WARNING!** Ensure that you read, understand and apply the safety instructions in Section 2.
 - 4.1. Confirm that the bearing is retained by interference fit (parallel or taper) only.
 - 4.2. Assemble splitter around rear of bearing and clamp together using the studs and nuts (fig.1.A & B) provided.
 - 4.3. Screw the fully threaded ends of the two puller rods (fig.1.C) into the splitter.
 - 4.4. Remove nuts (fig.1.D) from free ends of rods and place yoke (fig.1.E) over thread shanks.
 - 4.5. Retain yoke with flat washers provided (fig.1.F) and nuts, but do not tighten at this stage.
 - 4.6. Adjust ram T-handle (fig.2.A) so that tommy bar (fig.2.B) is approximately 80mm above ram end cap (see fig.2) and screw ram body into yoke until ram piston (fig.1.G) contacts end of shaft. If shaft has a 'centre' machining fit centre adaptor to piston before screwing ram down. If ram will not reach shaft use extension piece(s). **Note: Only use centre adaptor where end of shaft has a matching 'centre' machining. PS985 contains a plug which provides a thrust pad for the piston in applications where the shaft is hollow.**
 - 4.7. Adjust position of yoke to get ram piston on shaft centre and then tighten yoke retaining nuts.
 - 4.8. Turn T-handle clockwise, by hand only, to pull workpiece from shaft.
 - 4.9. Do not screw T-handle in further than 25mm (1") from end of the ram (see fig.2). If workpiece requires additional movement then unscrew T-handle to 80mm from end of ram, screw ram body down so that centre adaptor again contacts shaft and then continue to draw workpiece up shaft.
- IMPORTANT:** The maximum safe load for the puller can be achieved by hand effort alone. **The use of tools or levers on the tommy bar to increase the load will damage the splitter and may result in injury.** Such misuse will also invalidate the warranty.
- WARNING!** If the workpiece does not move when maximum puller force is applied, **DO NOT** hit it, or the puller, in an attempt to jar it free. Damage to puller/workpiece and personal injury may result. Use a larger capacity puller.

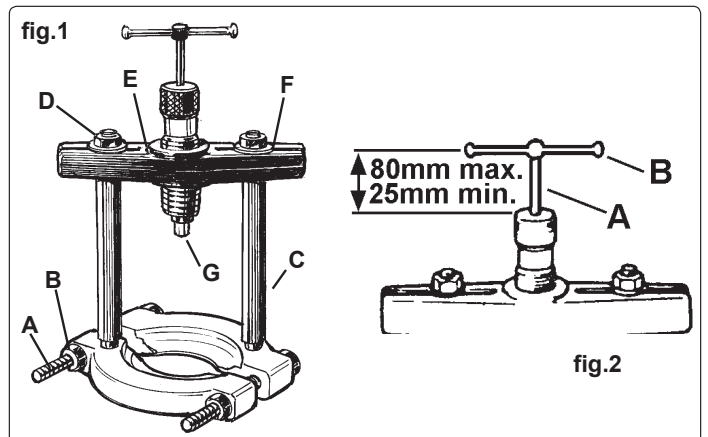

5. MAINTENANCE

5.1. GENERAL

- 5.1.1. Keep all items clean and lightly oiled. Keep all threads free from grit and lubricate the ram regularly.
- 5.1.2. Store the ram in the closed position to prevent piston surface corrosion.

5.2. TO CHANGE OIL in ram

IMPORTANT: The hydraulic system operates on a specially formulated oil which must be replaced from time to time. Use Sealey Hydraulic Jack Oil, available from your authorised Sealey dealer. Quote model number: HJO500MLS for 1 x 500ml bottle or PS982/OIL for 15grms of oil for a single refill.

WARNING! Use of any other oil in ram may cause ram to fail and will invalidate your warranty. Wear appropriate eye, face and hand protection.

- 5.2.1. Dismantle by removing the ram cover (fig.3.2) with soft jaw grips (fig.3.A) (body may have to be held in a soft jaw vice, ensure body thread is not damaged). Caution! The cover is spring loaded, take care when removing. Carefully remove components 2, 3, and 4 from the cylinder.
- 5.2.2. Screw T-handle (fig.4.5) down as far as it will go, then unscrew and remove it from the body (fig.4.5).
- 5.2.3. Push a narrow screw driver (fig.4.9), or a rod of appropriate diameter, down the small opening in head of ram (B), in order to push components 6, 7, and 8, plus the oil, out of the main cylinder. Note: A medium force may be required.
- 5.2.4. Remove remaining oil from main cylinder, clean all components and replace any showing signs of damage or wear.

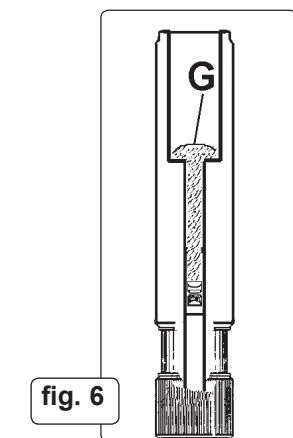
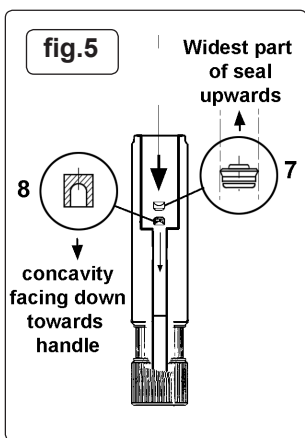
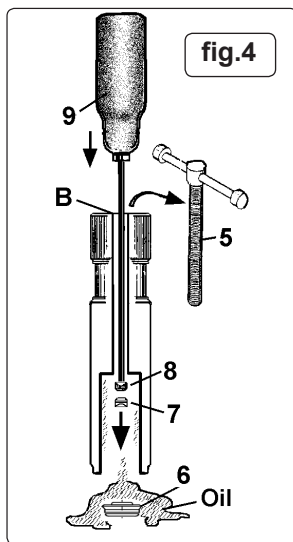
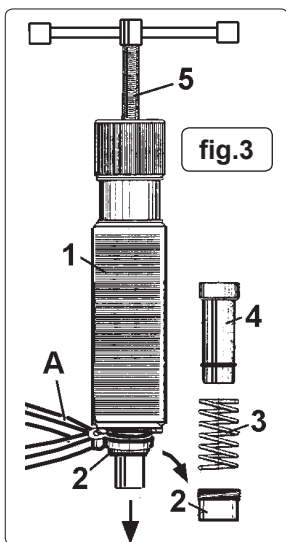

- 5.2.5. Take small seal and piston (fig.5.7 & 8) and gently push them down the narrow bore of the cylinder ensuring the metal piston (8) is first, with the concave face pointing in the direction of the T-handle, and the seal (fig.5.7) second, with the widest part of the seal facing upwards towards the main cylinder (fig.5). Push into bore as far as possible.
- 5.2.6. Pour 15grms of oil into the bore (fig.6). Insert larger seal (fig.7.6) as shown, with the widest part of the seal facing downwards into the bore. Push down into main cylinder as far as 'X' (fig.7) followed by piston (fig.7.4) and spring (fig.7.3).
- 5.2.7. Refit (do not overtighten) ram cover (fig.7.2) and replace T-handle (fig.7.5).

WARNING! The correct orientation of pistons and seals in the ram is critical.

- 5.2.8. Screw T-handle into ram until it contacts small piston and then turn a further two or three times.
- 5.2.9. Remove T-handle and firmly bounce the ram piston (fig.8) on a hard, but non-damaging, surface 6 to 10 times to consolidate the oil. Replace the T-handle, wipe clean and the ram is ready for use.

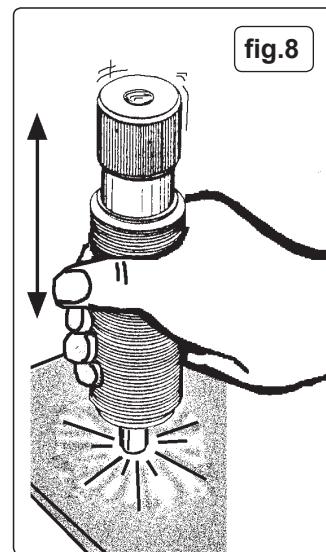
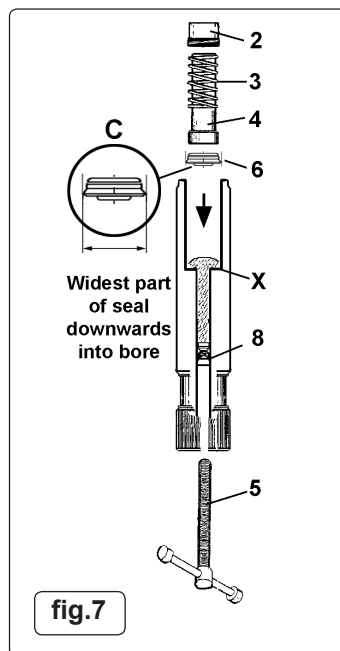

6. SERVICE PARTS & NOTES

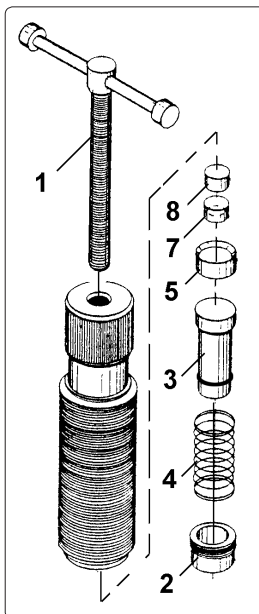

6.1 MAINTENANCE OF EARLY MODELS. Please note that earlier models of the PS990 were filled with a hydraulic grease.

WARNING! Do not put oil into units previously filled with grease as the seals will be configured for grease only and will leak if used with oil.

6.2 CONVERTING OLD UNITS TO OIL

The old type grease filled PS990 can be converted for use with oil by replacing the internal components with those supplied in the repair kit shown on left Part No PS982/8002. Do not mix old and new components. A single 15grm refill of oil may be obtained by quoting Part No.PS982/OIL

NOTE: It is our policy to continually improve products and as such we reserve the right to alter data, specifications and component parts without prior notice.

IMPORTANT: No liability is accepted for incorrect use of this product.

WARRANTY: Guarantee is 12 months from purchase date, proof of which will be required for any claim.

INFORMATION: For a copy of our catalogue and latest promotions call us on 01284 757525 and leave your full name, address and postcode.



Sole UK Distributor
Sealey Group,
Bury St. Edmunds, Suffolk.

01284 757500
01284 703534

www.sealey.co.uk
sales@sealey.co.uk