

Thank you for purchasing a Sealey Product. Manufactured to a high standard this product will, if used according to these instructions and properly maintained, give you years of trouble free performance.



**IMPORTANT: PLEASE READ THESE INSTRUCTIONS CAREFULLY. NOTE THE SAFE OPERATIONAL REQUIREMENTS, WARNINGS AND CAUTIONS. USE THIS PRODUCT CORRECTLY AND WITH CARE FOR THE PURPOSE FOR WHICH IT IS INTENDED. FAILURE TO DO SO MAY CAUSE DAMAGE OR PERSONAL INJURY AND WILL INVALIDATE THE WARRANTY. PLEASE KEEP INSTRUCTIONS SAFE FOR FUTURE USE.**

### 1. SAFETY INSTRUCTIONS

- ✓ Ensure the dispenser is on a reasonably flat, level floor before loading.
- ✓ Ensure that all fittings are tight and secure.
- ✓ Be aware that the paper cutting blades are sharp, handle with care.
- x **DO NOT** use the dispenser for any purpose other than that for which it is designed.

### 2. ASSEMBLY

Numbers in **BOLD** refer to the diagram in Fig.1

- 2.1 To assemble the side frames compress the silver latch button at the top of the front frame **1** and insert the tube into the back frame tube **1A** until they snap together.
- 2.2 Onto each end of the two paper bars **20** slide a paper holding ring **5** followed by a washer **16**, holding spring **17** and another washer **16**, followed by a paper holding ring **5**. Insert a screw **12** into the threaded block on each holding ring.
- 2.3 Attach the side frames to each end of the paper bars as shown in the main drawing using the four wing bolts **13**.
- 2.4 Fit the bottom tool tray between the side frames and bolt it to each leg using screw **10**, nut **22** and washer **23**.
- 2.5 Attach the upper paper blade **7** to the front of the frame using two screws **10**, two nuts **22** and two washers **23**.
- 2.6 Attach the lower cutting blade **7** to the front of the frame using two screws **10**, two nuts **22** and two washers **23**.
- 2.7 Attach a paper spring **7A** to the back edge of each cutting blade. Hook one end of the spring to the notched back corner of the metalwork and stretch it across and hook it to the other back corner. Take care to avoid the cutting blade teeth when doing this.
- 2.8 To assemble the four tape reels as shown in Fig.2 take a long bolt **14** and screw on to it a wing nut **6** then drop a washer **23** onto it followed by a metal bush **21**. Slide a reel **8** over the bolt and onto the bush ensuring that it is the right way round. Retain the assembly using another washer followed by a wing nut **6**. After the nut has been tightened the reel should still run freely on the bush. Attach another nut to the bolt and insert the bolt through the frame in one of the four places indicated on the main drawing. Retain the assembly in place using a nut **22** and a washer **23**.
- 2.9 Attach the small tool tray **15** to the side of one of the frames using two screws **10**, two nuts **22** and two washers **23**. The nuts and washers should be on the inside of the tray.
- 2.10 Attach the hanger **9** to the side of the opposite frame at the same level as the top tray. Insert the ends of the hanger into the holes in the side of the frame, tip the hanger forwards so that the first bend in either end of the hanger is inside each frame tube.
- 2.11 The MK66.V3 has a solid rod axle **4** with holes at either end to accept cotter pins **11**. Slide the axle through the holes near the bottom of each rear leg and retain it with a cotter pin. Secure by bending the pin back onto itself.
- 2.12 Slide a wheel spacer **24**, then a wheel **3** onto each end of the axle and retain them with a cotter pin **11** through the axle. Secure by bending the pin back onto itself.

Fig.1

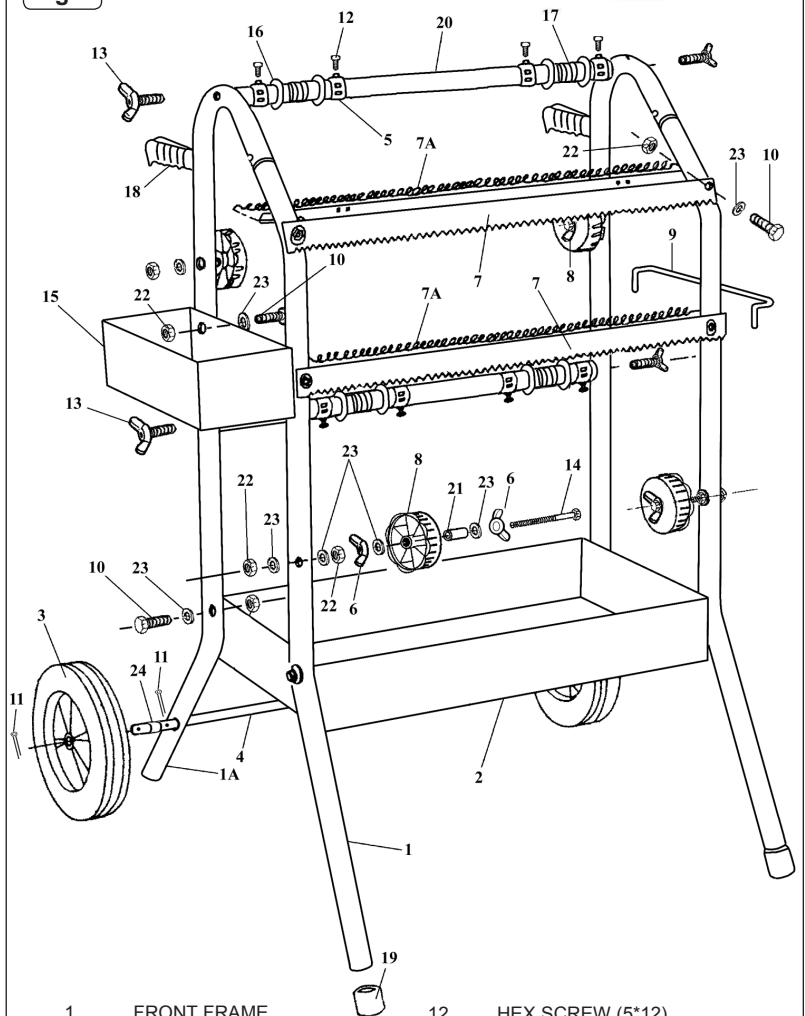

1	FRONT FRAME	12	HEX SCREW (5*12)
1A	REAR FRAME	13	BOLT THREAD WING NUT
2	TOOL TRAY (LARGE)	14	LONG BOLT
3	WHEEL	15	SMALL TOOL TRAY
4	AXLE	16	PAPER HOLDING WASHER
5	PAPER HOLDING RING	17	PAPER HOLDING SPRING
6	WING NUT	18	HANDLE GRIP
7	CUTTING BLADE	19	FRAME FOOT
7A	CUTTING BLADE SPRING	20	PAPER BAR
8	TAPE REEL	21	BUSHING FOR TAPE REEL
9	HANGER BAR	22	NUT M6
10	SCREW	23	WASHER M6
11	COTTER PIN	24	SPACER

### 3. USING THE DISPENSERS

- 3.1 Remove either the upper or lower paper bar from the frame by unscrewing and removing the wing bolts at either end.
- 3.2 On one side of the bar loosen the screws of the black paper holding rings and remove the rings, spring and washers from the end of the bar. Remove the cardboard tube centre of the last roll from the bar.
- 3.3 Slide the the paper bar through the centre of the new paper roll and refit the washers, spring and rings to the end of the bar. Temporarily tighten the screws in the holding ring.
- 3.4 To refit the loaded bar to the frame get a second person or persons to support the paper roll while the wing bolts are fitted at either end of the bar. The paper should be coming off the top of the roll. Once loaded, check that the roll is centrally placed on the paper bar and make any necessary adjustments using the black holding rings.
- 3.5 Push a roll of masking tape onto each tape dispensing reel and spin it to make sure the tape is running true. Check that the tape dispensers are aligned with the ends of the paper roll as shown in Fig.3. (The centre line of the tape should align with the edges of the paper roll.) The position of the tape dispensers can also be adjusted as shown in Fig.2. To increase or decrease dimension 'X' loosen the wing nut 'Z' and wing nut 'Y' up or down the bolt as required. Retighten the wing nut.
- 3.6 Pull about 450mm of paper from the roll and feed it between the paper spring and the back edge of the adjacent cutting blade.
- 3.7 Pull tape from each dispenser in turn and stick it to the paper roll so that it is half on and half off the paper edges. Check the alignment of the tapes and make any further adjustments required to the positions of the tape dispensers.
- 3.8 Slowly pull the paper from the roll and check that the tapes feed correctly onto the edges of the paper.
- 3.9 Tear the paper off with an upward movement against the down facing teeth of the paper blade. Keep hands well away from the blade when doing this.
- 3.10 Load the other paper bar as described above.

**NOTE:** A fully loaded frame is quite heavy. Take care when moving it and always leave it in a stable position.

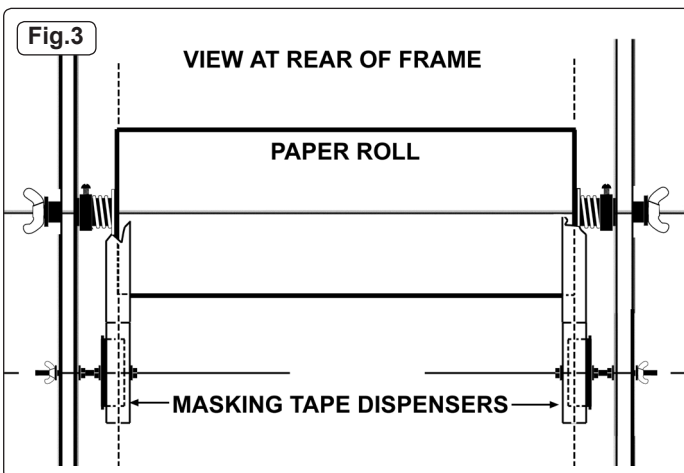
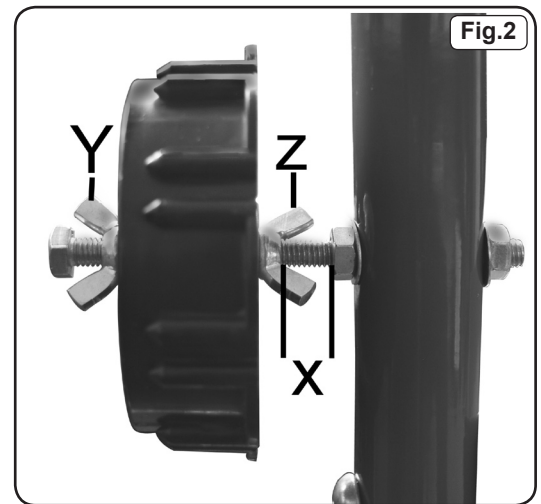

**NOTE:** It is our policy to continually improve products and as such we reserve the right to alter data, specifications and component parts without prior notice.

**IMPORTANT:** No liability is accepted for incorrect use of this product.

**WARRANTY:** Guarantee is 12 months from purchase date, proof of which will be required for any claim.

**INFORMATION:** For a copy of our catalogue and latest promotions call us on 01284 757525 and leave your full name, address and postcode.

**SEALEY**

**POWER  
PRODUCTS**

Sole UK Distributor, Sealey Group,  
Kempson Way, Suffolk Business Park,  
Bury St. Edmunds, Suffolk,  
IP32 7AR



01284 757500



01284 703534



[www.sealey.co.uk](http://www.sealey.co.uk)



[sales@sealey.co.uk](mailto:sales@sealey.co.uk)