



SPARE PARTS LISTING SHEET FOR

# 405mm Variable Speed Fretsaw with Flexible Drive Shaft

Stock No.22791

Part No.FS405V

KEY No.	PART No.	STOCK No.	DESCRIPTION
1	YFS405V-01	29398	Screw.
2	YFS405V-02	29399	Washer.
3	YFS405V-03	29400	Side panel.
4	YFS405V-04	29401	Nut.
5	YFS405V-05	29402	Spring washer.
6	YFS405V-06	29403	Base.
7	YFS405V-07	29404	Oil cap.
8	YFS405V-08	29405	Left arm cover.
9	YFS405V-09	29411	Blade tension assembly.
10	YFS405V-10	29459	Spring.
11	YFS405V-11	29460	Pressure plate.
12	YFS405V-12	29461	Spring washer.
13	YFS405V-13	29462	Screw.
14	YFS405V-14	29463	Lower arm.
15	YFS405V-15	29464	Upper arm.
16	YFS405V-16	29465	Bearing.
17	YFS405V-17	29466	Screw.
18	YFS405V-18	29467	Clip.
19	YFS405V-19	29468	Right arm cover.
20	YFS405V-20	29469	Spring washer.
21	YFS405V-21	29470	Screw.
22	YFS405V-22	29471	Screw.
23	YFS405V-23	29472	Bellows lock.
24	YFS405V-24	29473	Screw.
25	YFS405V-25	29474	Lamp assembly.
26	YFS405V-26	29475	Bulb.
27	YFS405V-27	29476	Nut.
28	YFS405V-28	29477	Bellows.
29	YFS405V-29	29478	Plate.
30	YFS405V-30	29479	Screw.
31	YFS405V-31	29480	Upper blade guide.
32	YFS405V-32	29481	Washer.
33	YFS405V-33	29482	Screw.
34	YFS405V-34	29483	Cushion.
35	YFS405V-35	-	Blades.
36	YFS405V-36	29488	Screw.

KEY No.	PART No.	STOCK No.	DESCRIPTION
37	YFS405V-37	29489	Screw.
38	YFS405V-38	29490	Connector.
39	YFS405V-39	29491	Ball bearing.
40	YFS405V-40	29492	Nut.
41	YFS405V-41	29493	Plate.
42	YFS405V-42	29494	Screw.
43	YFS405V-43	29508	Cushion.
44	YFS405V-44	29509	Screw.
45	YFS405V-45	29510	Lower blade guide.
46	YFS405V-46	29511	Locking nut.
47	YFS405V-47	29512	Shaft.
48	YFS405V-48	29513	Screw.
49	YFS405V-49	29514	Cover.
50	YFS405V-50	29515	Drop foot.
51	YFS405V-51	29516	Washer.
52	YFS405V-52	29535	Screw.
53	YFS405V-53	29551	Plate.
54	YFS405V-54	29553	Spring washer.
55	YFS405V-55	29554	Screw.
56	YFS405V-56	29555	Screw.
57	YFS405V-57	29556	Washer.
58	YFS405V-58	29569	Spring.
59	YFS405V-59	29585	Screw.
60	YFS405V-60	29592	Table bracket.
61	YFS405V-61	29600	Pointer.
62	YFS405V-62	29618	Table arm.
63	YFS405V-63	29642	Table.
64	YFS405V-64	29651	Table insert.
65	YFS405V-65	29652	Transformer.
66	YFS405V-66	29653	Transformer box.
67	YFS405V-67	29654	Washer.
68	YFS405V-68	29655	Screw.
69	YFS405V-69	29656	Screw.
70	YFS405V-70	29657	Pulley.
71	YFS405V-71	29658	Motor.
72	YFS405V-72	29659	Switch box.

**Helpline: (023) 8049 4344. Sales Desk: (023) 8049 4333. General Enquiries: (023) 8026 6355.**

DRAPER TOOLS LTD, HURSLEY ROAD, CHANDLER'S FORD, EASTLEIGH, HANTS. SO53 1YF. U.K. internet: www.drapertools.co.uk e-mail: sales@drapertools.com



SPARE PARTS LISTING SHEET FOR

# 405mm Variable Speed Fretsaw with Flexible Drive Shaft

Stock No.22791

Part No.FS405V

KEY No.	PART No.	STOCK No.	DESCRIPTION
73	YFS405V-73	29660	Power cord connector.
74	YFS405V-74	29663	Screw.
75	YFS405V-75	29664	Variable speed regulator.
76	YFS405V-76	29665	Circuit board.
77	YFS405V-77	29666	Locking nut.
78	YFS405V-78	29667	Switch box cover.
79	YFS405V-79	29668	On/off switch.
80	YFS405V-80	29670	Variable speed dial.
81	YFS405V-81	29671	Screw.
82	YFS405V-82	29672	Plug and cable.
83	YFS405V-83	29673	Shaft.
84	YFS405V-84	29674	Bearing.
85	YFS405V-85	29698	Retaining ring.
86	YFS405V-86	29704	Retaining ring.

KEY No.	PART No.	STOCK No.	DESCRIPTION
87	YFS405V-87	29709	O-ring.
88	YFS405V-88	29836	Axle.
89	YFS405V-89	29837	Sleeve.
90	YFS405V-90	29838	Screw.
91	YFS405V-91	29839	Safety cap.
92	YFS405V-92	29866	Flexible shaft.
93	YFS405V-93	29942	Belt cover.
94	YFS405V-94	29943	Pin.
95	YFS405V-95	30040	Timing belt.
96	YFS405V-96	30041	Pulley.
97	YFS405V-97	30042	Shield.
98	YFS405V-98	30043	Air hose.
99	YFS405V-99	30044	Screw.
100	YFS405V-100	30045	Tube.

**Helpline:** (023) 8049 4344. **Sales Desk:** (023) 8049 4333. **General Enquiries:** (023) 8026 6355.

DRAPER TOOLS LTD, HURSLEY ROAD, CHANDLER'S FORD, EASTLEIGH, HANTS. SO53 1YF. U.K. internet: [www.drapers.co.uk](http://www.drapers.co.uk) e-mail: [sales@drapertools.com](mailto:sales@drapertools.com)



SPARE PARTS DRAWING SHEET FOR

# 405mm Variable Speed Fretsaw with Flexible Drive Shaft

Stock No.22791

Part No.FS405V

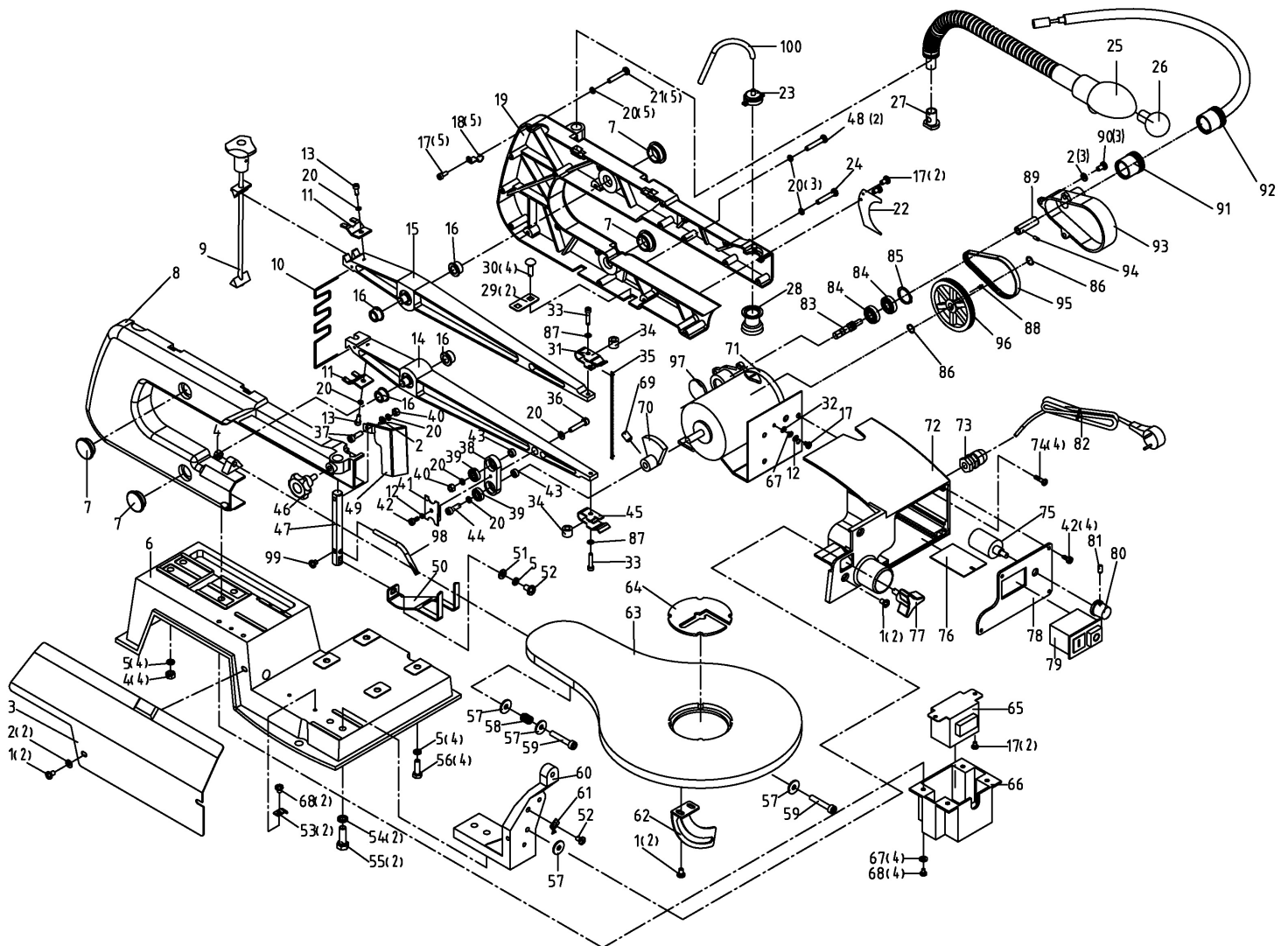

**Helpline:** (023) 8049 4344. **Sales Desk:** (023) 8049 4333. **General Enquiries:** (023) 8026 6355.

DRAPER TOOLS LTD, HURSLEY ROAD, CHANDLER'S FORD, EASTLEIGH, HANTS. SO53 1YF. U.K. internet: [www.drapertools.co.uk](http://www.drapertools.co.uk) e-mail: [sales@drapertools.com](mailto:sales@drapertools.com)

RWDH260210