



HEAVY-DUTY MOBILE TOOL & PARTS TROLLEY WITH 5 DRAWERS AND LOCKABLE TOP

MODELS: **AP890M & AP890MHV**

Thank you for purchasing a Sealey product. Manufactured to a high standard, this product will, if used according to these instructions, and properly maintained, give you years of trouble free performance.

IMPORTANT: PLEASE READ THESE INSTRUCTIONS CAREFULLY. NOTE THE SAFE OPERATIONAL REQUIREMENTS, WARNINGS & CAUTIONS. USE THE PRODUCT CORRECTLY AND WITH CARE FOR THE PURPOSE FOR WHICH IT IS INTENDED. FAILURE TO DO SO MAY CAUSE DAMAGE AND/OR PERSONAL INJURY AND WILL INVALIDATE THE WARRANTY. KEEP THESE INSTRUCTIONS SAFE FOR FUTURE USE.



Refer to instructions

1. SAFETY

- WARNING!** Ensure Health & Safety, local authority, and general workshop practice regulations are adhered to when using this trolley.
- ✓ Always load evenly with the centre of gravity of the load as near centre of the trolley as possible.
- ✗ **DO NOT** overload the trolley - see section 3.
- ✓ Use the trolley in a suitable work area.
- ✓ Keep the work area clean, uncluttered and ensure there is adequate lighting.
- ✓ Keep the trolley clean and tidy in accordance with good workshop practice.
- ✗ **DO NOT** use the trolley for any purpose other than that for which it is designed.
- ✗ **DO NOT** stand on the trolley, use it as a ladder or allow others to ride on the trolley.
- ✓ Use the wheel locks to prevent the trolley from inadvertently moving.
- ✗ **DO NOT** leave unattended, especially when loaded, unless the wheels are locked, chocked or the trolley otherwise secured.
- ✗ **DO NOT** use trolley on uneven ground and do not run over curbs or steps - use a ramp.
- ✗ **DO NOT** use trolley if any part is significantly damaged, paying particular attention to the wheels.
- ✓ Keep children and unauthorised persons away from the work area.

2. INTRODUCTION

Five drawer garage & workshop trolley. With an overall capacity of 320kg evenly distributed. The five drawers are lined with non-slip liners and have ball-bearing slides as standard. Features rear locking mechanism which engages once the lockable top lid is closed, adding extra security. There are extra hand tool storage slots situated on either side within the top compartment. Lined Lower shelf is ideal for larger parts or tool storage. Fitted with a side handle, two fixed castors and two swivel castors with toe brakes to aid manoeuvrability around the workshop or garage.

3. SPECIFICATION

Model No.:AP890M/HV
 Capacity: Overall: 320kg
 Top tray and Bottom Tray: 80kg each
 2 Small drawers:20kg each
 Other 3 drawers:40kg each
 Evenly distributed.
 Drawer Size:
 Small drawer (x2) (W x D x H): 295 x 430 x 55mm
 Small deep drawer (x1): 300 x 430 x 120mm
 Medium drawer (x1): 624 x 430 x 70mm
 Large drawer (x1): 624 x 430 x 120mm
 Overall Size: 940 x 515 x 1050mm
 Shelf Size (W x D):
 Top compartment: 660 x 480 x 120mm
 Bottom Tray: 770 x 490 x 90mm



4. ASSEMBLY

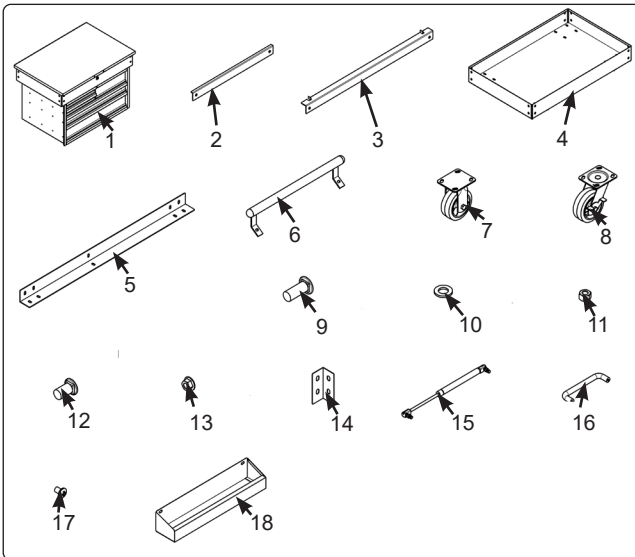

Item	Description
1	Drawer Unit
2	Brace (End)
3	Brace (Front)
4	Bottom Tray
5	Leg
6	Side Handle
7	Castor (Fixed)
8	Castor (Locking)
9	Carriage Bolt M8 x 20mm
10	Plain Washer (M8)
11	Nut (M8)
12	Carriage Bolt (M8 x 16mm)
13	Flanged Nut (M8)
14	Corner Stiffener
15	Gas Strut
16	Lid Handle
17	Bolt M4 x 6mm
18	Can/Tool Tray

NOTE: DO NOT tighten fixings until all parts are correctly aligned.

4.1. CASTOR ASSEMBLY

- 4.1.1. Using items 9, 10 and 11, fix locking castors (item 8) to one end of the underside of bottom tray (item 4).
- 4.1.2. Using items 9, 10 and 11, fix fixed castors (item 7) to other end of the underside of bottom tray (item 4).

4.2. LEG ASSEMBLY (fig.1)

NOTE: Holes of 26mm pitch centre are to be fitted to outer edge of bottom tray (item 4).

- 4.2.1. Using items 12 and 13, fix legs (item 5) to outer edge of bottom tray (item 4).

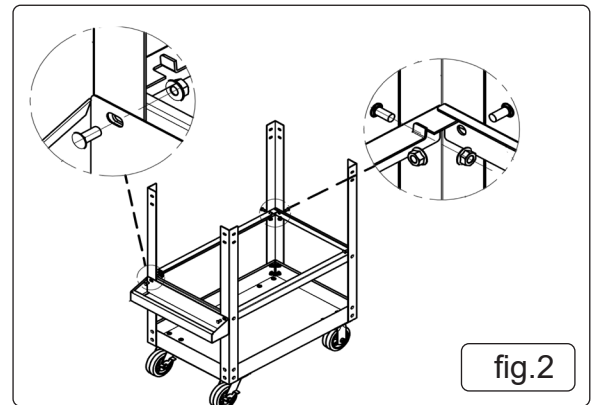
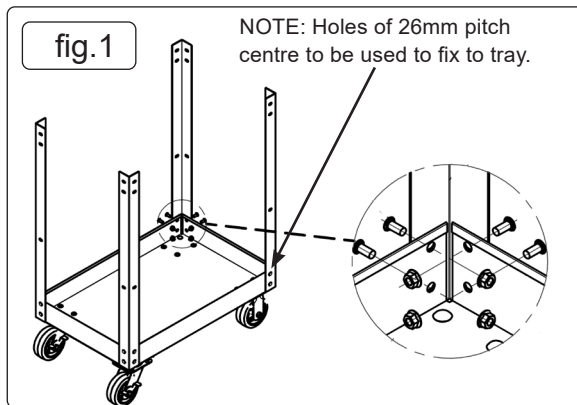

4.3. BRACES ASSEMBLY (fig.2)

- 4.3.1. Using items 12 and 13 fit braces (items 2 and 3) to legs (items 5).
- 4.3.2. Using items 12 and 13 fit tray (item 18) to brace and leg (item 2 and 5). at locking castor end of unit.

4.4. DRAWER UNIT ASSEMBLY (fig.3)

- 4.4.1. Fit drawer unit (item 1) into inside of legs. Place corner stiffener (item 14) into the corner and fix stiffener and tray in place using items 12 and 13.

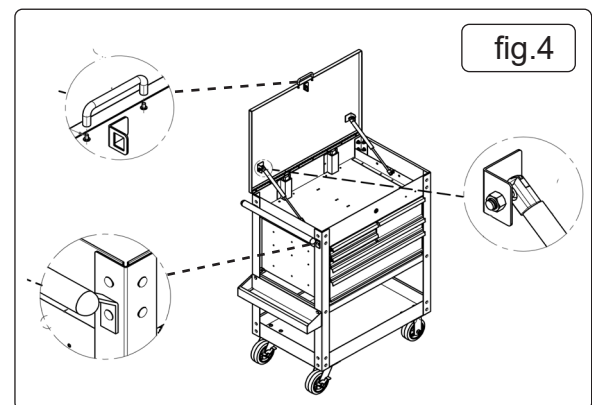
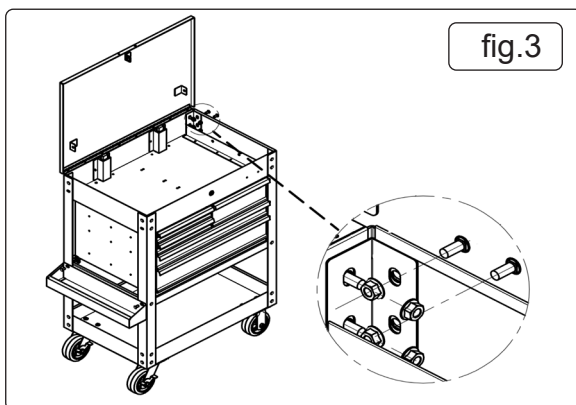

4.5. ADDITIONAL ATTACHMENTS (fig.4)

- 4.5.1. Fit lid handle (item 16) to lid using items 17.
- 4.5.2. Fit side handle (item 6) to frame using items 9 and 13.
- 4.5.3. Fit gas struts (item 15) between drawer unit and lid using item 11.

5. MAINTENANCE

- 5.1. Periodically lubricate castors and tighten all hardware.
- 5.2. Clean the surfaces with a soft cloth and a mild water/detergent solution.



ENVIRONMENT PROTECTION

Recycle unwanted materials instead of disposing of them as waste. All tools, accessories and packaging should be sorted, taken to a recycling centre and disposed of in a manner which is compatible with the environment. When the product becomes completely unserviceable and requires disposal, drain any fluids (if applicable) into approved containers and dispose of the product and fluids according to local regulations.

Note: It is our policy to continually improve products and as such we reserve the right to alter data, specifications and component parts without prior notice.

Important: No Liability is accepted for incorrect use of this product.

Warranty: Guarantee is 12 months from purchase date, proof of which is required for any claim.



REGISTER YOUR
PURCHASE HERE

Sealey Group, Kempson Way, Suffolk Business Park, Bury St Edmunds, Suffolk. IP32 7AR



01284 757500



01284 703534



sales@sealey.co.uk



www.sealey.co.uk