



# MODULAR FLAT SHELF VAN STORAGE UNIT SERIES

MODEL NO: APMSV01, APMSV02, APMSV03

Thank you for purchasing a Sealey product. Manufactured to a high standard, this product will, if used according to these instructions, and properly maintained, give you years of trouble free performance.

**IMPORTANT:** PLEASE READ THESE INSTRUCTIONS CAREFULLY. NOTE THE SAFE OPERATIONAL REQUIREMENTS, WARNINGS & CAUTIONS. USE THE PRODUCT CORRECTLY AND WITH CARE FOR THE PURPOSE FOR WHICH IT IS INTENDED. FAILURE TO DO SO MAY CAUSE DAMAGE AND/OR PERSONAL INJURY AND WILL INVALIDATE THE WARRANTY. KEEP THESE INSTRUCTIONS SAFE FOR FUTURE USE.



Refer to instruction manual

## 1. SAFETY

- WARNING!** Ensure Health & Safety, local authority, and general workshop practice regulations are adhered to when assembling or using this cabinet.
- ✓ Locate cabinet in a suitable work area when assembling it.
- ✓ Keep the work area clean, uncluttered and ensure there is adequate lighting.
- ✓ Keep the cabinets clean and tidy in accordance with good workshop practice.
- ✓ Keep children and unauthorised persons away from the assembly area.
- ✓ It is recommended that two competent people are involved in assembling these units.
- ✓ Consult vehicle manufacturers hand book / guide book for fixing recommendation in the vehicle.
- ✓ Load heavier items low down in the unit.
- ✗ **DO NOT** use the cabinets for any purpose other than that for which they are designed.
- ✗ **DO NOT** clean the cabinet with any solvents which may damage the surfaces or the protective coating.
- ✗ **DO NOT** move the cabinet when there are items placed inside.
- ✗ **DO NOT** overload the cabinet.

## 2. INTRODUCTION

### Model No. APMSV01

Modular van storage system designed to fit medium and large vans. Designed to fit close to the interior walls of the van freeing up precious floor space. Robust steel construction with perforated tool side panels for extra organisation. Three shelves that can be height adjusted in 25mm increments. Eight dividers that adjust every 75mm ideal for parts trays and plastic parts bins. Supplied flat packed with six brackets to ensure security and rigidity. Lockable door APMSV03 available (not included).

### Model No. APMSV02

Modular van storage system, universally designed to fit multiple medium and large vans. Versatile slanted shelves and dividing system allows you to maximise your storage space with minimal effort. Designed to fit close to the interior walls of the van freeing up precious floor space. Robust steel construction with perforated tool side panels for extra organisation. Three slanted shelves that can be height adjusted in 25mm increments. One flat shelf with two steel dividers that adjust every 75mm. Supplied flat packed with six brackets to ensure security and rigidity. Lockable door APMSV03 available (not included).

### Model No. APMSV03

Modular van storage system lockable door front. Designed to fit either APMSV01 or APMSV02 and create a secure section to keep valuables safe. Versatile sprung system allows you to place the door in any section of the frame to create the lockable space. Robust steel construction with strong cylinder lock supplied with two keys. Easy self-assembly.

## 3. SPECIFICATION

**Model no:**.....APMSV01

Overall size (W x D x H) :.....926 x 380 x 1300mm

Shelf size (x4): .....925 x 370 x 225mm

Shelf Partitions..... 8

**Model no:**.....APMSV02

Overall size (W x D x H) :.....926 x 380 x 1300mm

Shelf size (x4): .....925 x 370 x 225mm

Partition Plates..... 2

**Model no:**.....APMSV03

## 4. CABINET ASSEMBLY

4.1. Assemble the cabinet following the figures below, referencing the parts list and diagram overleaf. Use a trestle table or a workbench if required.

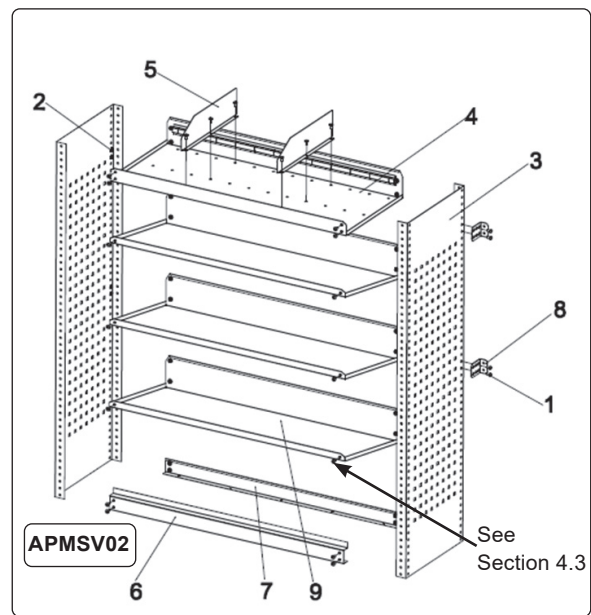
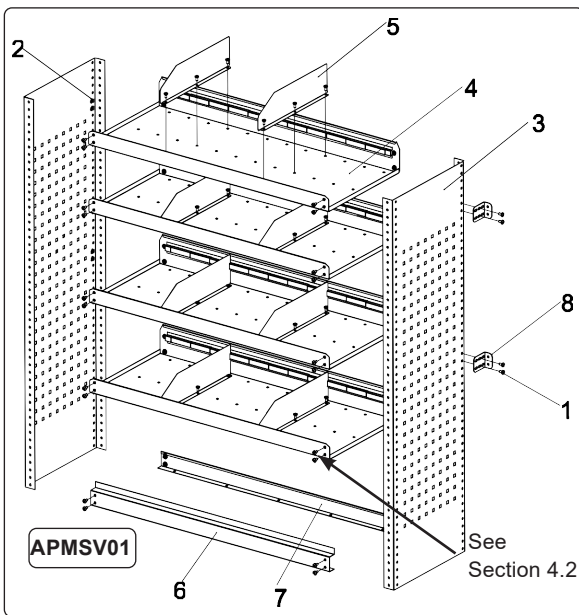

- 4.2. **APMSV01** : Assemble the lowermost shelf using the 16th and 17th fixing holes on the end plates (counting upwards from the bottom). This will enable a lockable door to be fitted if required. Shelf dividers can be arranged at 75mm where necessary.
- 4.3. **APMSV02** : Assemble the lowermost shelf using the 16th fixing hole on the end plates (counting upwards from the bottom). This will enable a lockable door to be fitted if required.
- 4.4. If required, two units can be bolted together using the holes at the top and bottom of each end panel.
- 4.5. Fixing brackets are supplied for wall fixing (item 8 in diagrams).

## 5. DOOR ASSEMBLY

- 5.1. Fit side brackets (item 5) to inside face of end plate with the lowermost hole aligning with the fourth hole up from the bottom of the end plate.
- 5.2. Fit the lateral plate (item 4) using the 15th fixing hole on the end plates (counting upwards from the bottom).
- NOTE:** Other doors can be fitted to each shelf if required.

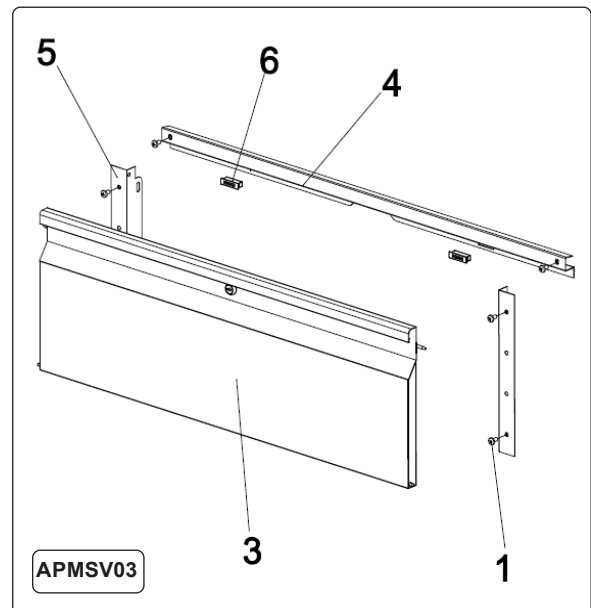

### ENVIRONMENT PROTECTION

Recycle unwanted materials instead of disposing of them as waste. All tools, accessories and packaging should be sorted, taken to a recycling centre and disposed of in a manner which is compatible with the environment. When the product becomes completely unserviceable and requires disposal, drain any fluids (if applicable) into approved containers and dispose of the product and fluids according to local regulations.

**Note:** It is our policy to continually improve products and as such we reserve the right to alter data, specifications and component parts without prior notice.

**Important:** No Liability is accepted for incorrect use of this product.

**Warranty:** Guarantee is 12 months from purchase date, proof of which is required for any claim.

Sealey Group, Kempson Way, Suffolk Business Park, Bury St Edmunds, Suffolk. IP32 7AR



01284 757500



01284 703534



sales@sealey.co.uk



www.sealey.co.uk