

Original Date:- 200999
 Version No.:- 4
 Date Modified:- 030401

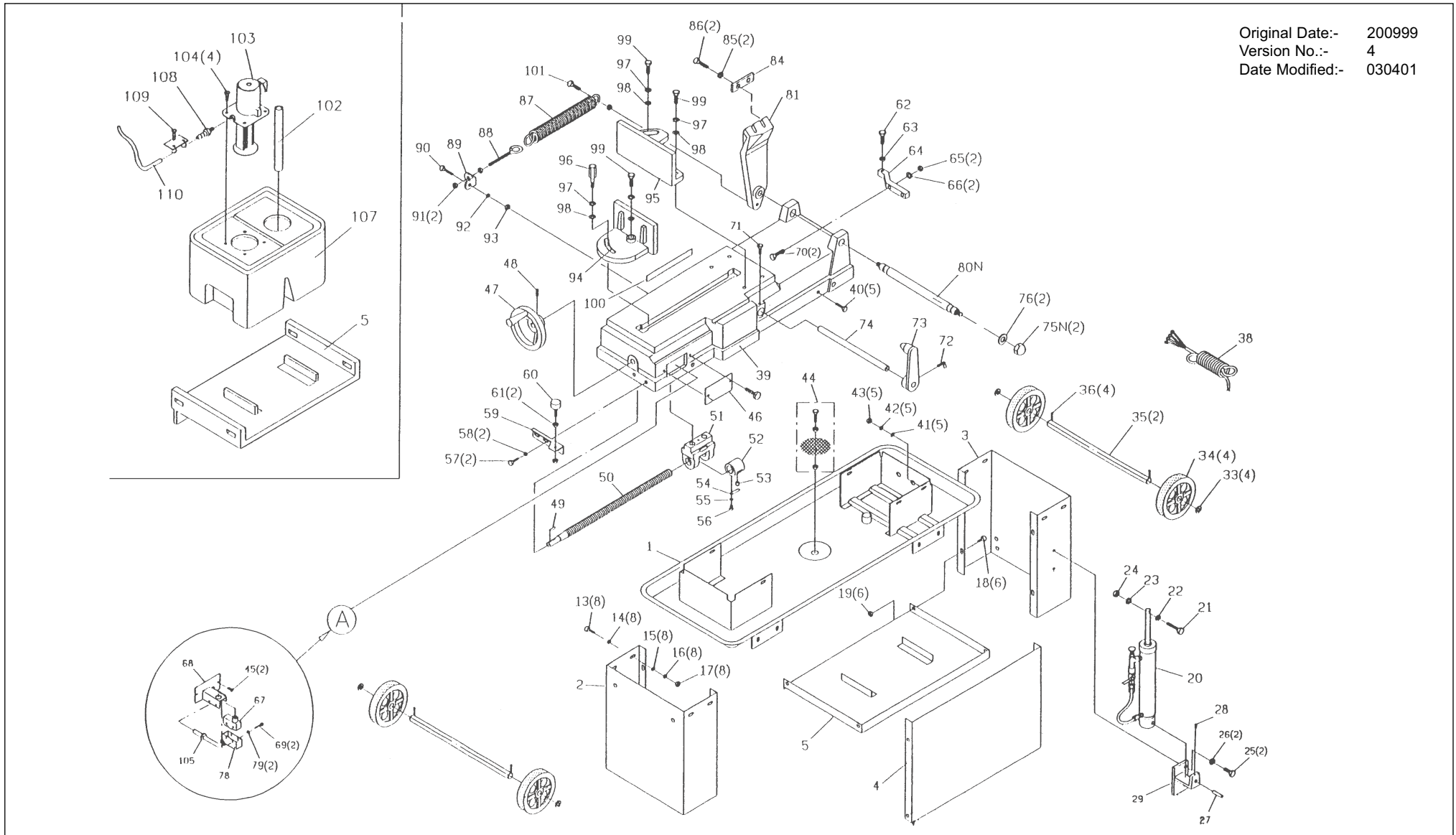

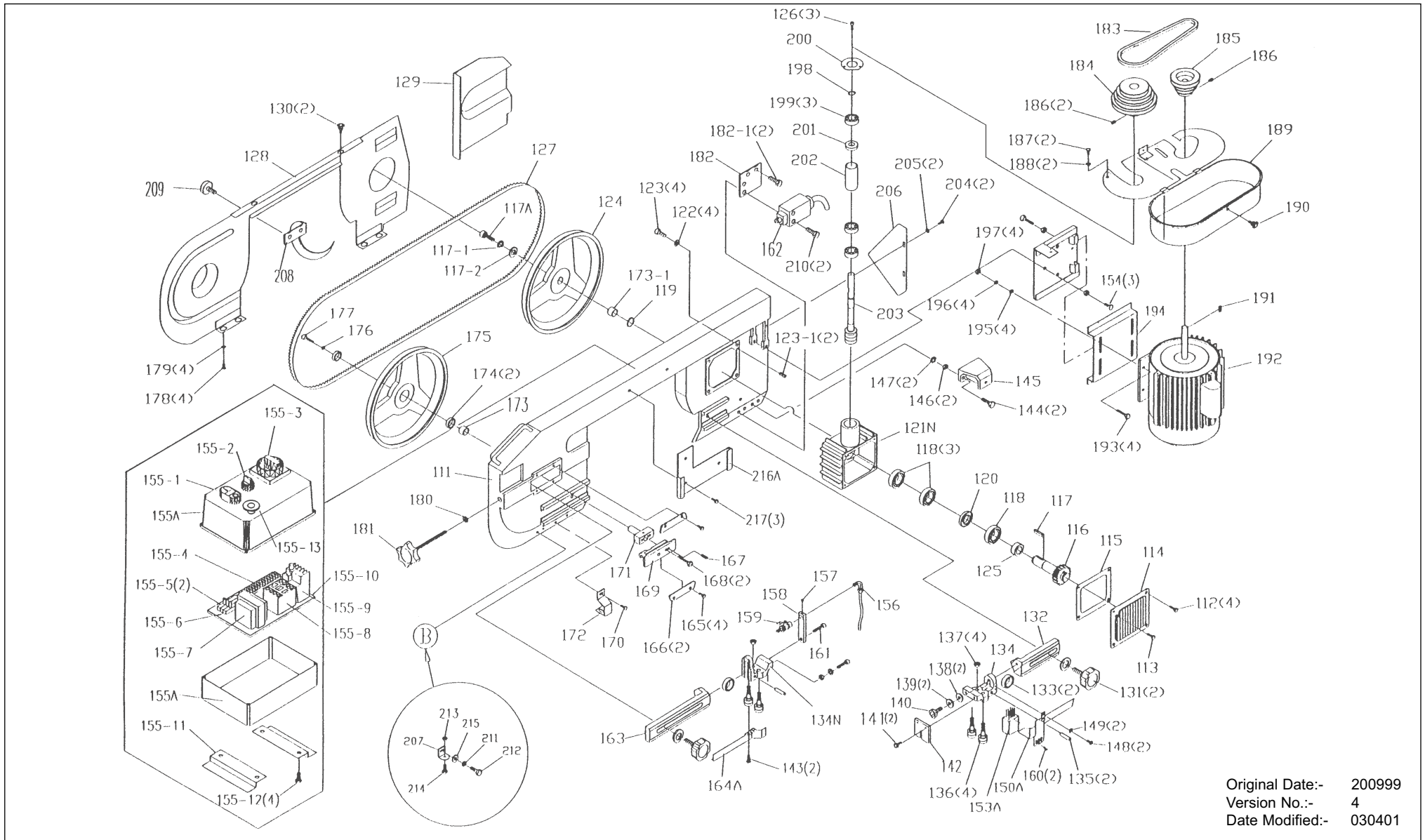

Original Date:- 200999
Version No.:- 4
Date Modified:- 030401



PARTS DIAGRAM & LIST FOR:
12" HORIZONTAL BANDSAW

Model No: **SM35CE**

Sole UK Distributor, Sealey Group, Bury St. Edmunds, Suffolk.

01284 757500 01284 703534 **E-mail:** sales@sealey.co.uk

ITEM	PART NO.	DESCRIPTION
1	SM35H/001	Pan, Bottom
2	SM35H/002	Leg, Left
3	SM35H/003	Leg, Right
4	SM35H/004	Skirt
5	SM35H/005	Shelf
13	SM35H/013	Screw, Hex Head 5/16 x 3/4"
14	SM35H/014	Washer, Spring 5/16"
15	SM35H/015	Washer, 5/16"
16	SM35H/016	Washer, Spring 5/16"
17	SM35H/017	Nut, 5/16"
18	SM35H/018	Screw, Hex Head 5/16 x 1/2"
19	SM35H/019	Nut, 5/16"
20	SM35H/020	Cylinder, Arm Lifting
21	SM35H/021	Screw, Hex Socket M10 x 40
22	SM35H/022	Washer, 3/8"
23	SM35H/023	Washer, Spring 3/8"
24	SM35H/024	Nut, M10
25	SM35H/025	Screw, Hex Head 3/8 x 1"
26	SM35H/026	Washer, Spring 3/8"
27	SM35H/027	Rod, Support
28	SM35H/028	Screw, Hex Head 1/4 x 3/8"
29	SM35H/029	Support, Bottom
33	SM35H/033	Washer
34	SM35H/034	Wheel, 5"
35	SM35H/035	Shaft, Wheel
36	SM35H/036	Pin, Cotter
38	SM35H/038	Cord, Electric, Assembly
39	SM35H/039	Table
40	SM35H/040	Screw, Hex Head 5/16 x 1"
41	SM35H/041	Washer, 5/16"
42	SM35H/042	Washer, Spring 5/16"
43	SM35H/043	Nut, 5/16"
44	SM35H/044	Filter
45	SM35H/045	Screw, Hex Head 3/16 x 3/8"
46	SM35H/046	Cover
47	SM35H/047	Wheel, Vice Handle
48	SM35H/048	Screw, Hex Head 5/16 x 1/2"

ITEM	PART NO.	DESCRIPTION
49	SM35H/049	Key, 5mm
50	SM35H/050	Lead Screw
51	SM35H/051	Seat, Nut
52	SM35H/052	Nut, Acme Thread
53	SM35H/053	Button
54	SM35H/054	Retainer
55	SM35H/055	Washer, Spring
56	SM35H/056	Screw, Hex Head M6 x 10
57	SM35H/057	Screw, Hex Head 5/16 x 3/4"
58	SM35H/058	Washer, Spring 5/16"
59	SM35H/059	Support Plate
60	SM35H/060	Screw, Stop
61	SM35H/061	Nut, 5/16"
62	SM35H/062	Screw, Hex Head 3/8 x 1-1/4"
63	SM35H/063	Nut, 3/8"
64	SM35H/064	Support, 90
65	SM35H/065	Nut, 3/8"
66	SM35H/066	Washer, Spring 3/8"
67	SM35CE/067	Switch, Limit (Cut-off)
68	SM35CE/068	Plate, Limit Switch
70	SM35H/070	Screw, Hex Head 3/8 x 1-1/2"
71	SM35H/071	Screw, Set 5/16 x 3/8"
72	SM35H/072	Screw, Thumb
73	SM35H/073	Block, Stop
74	SM35H/074	Rod, Stock Stop
75	SM35H/075	Nut, 1/2"
76	SM35H/076	Washer, 1/2"
78	SM35CE/078	Rubber Cover (Limit Switch)
80	SM35H/080	Shaft, Support
81	SM35H/081	Pivot Arm (New Type)
84	SM35H/084	Washer, 3/8"
85	SM35H/085	Washer, Spring
86	SM35H/086	Screw, Hex Head 3/8 x 1-1/2"
87	SM35H/087	Use SM35/091 Spring
88	SM35H/088	Rod, Spring Adjusting
89	SM35H/089	Bracket, Spring
90	SM35H/090	Screw, Hex Head 5/16 x 1-1/4"

ITEM	PART NO.	DESCRIPTION
91	SM35H/091	Nut, 5/16"
92	SM35H/092	Washer, Spring 5/16"
93	SM35H/093	Nut, 5/16"
94	SM35H/094	Vice, Front
95	SM35H/095	Vice, Rear
96	SM35H/096	Screw, Hex Head 3/8 x 1-1/4"
97	SM35H/097	Washer, Spring
98	SM35H/098	Washer
99	SM35H/099	Screw, Hex Head 3/8 x 1-1/4"
100	SM35H/100	Scale
101	SM35H/101	Screw, Hex Head 1/4 x 1-1/2"
102	SM35H/102	Hose
103	SM35H/103	Pump, Coolant
104	SM35H/104	Screw, Hex Head 1/4 x 5/8"
107	SM35CE/107	Coolant Tank (Plastic)
108	SM35H/108	Fitting, Hose
109	SM35H/109	Clamp, Hose
110	SM35H/110	Hose
111	SM35H/111	Bow, Saw
112	SM35H/112	Screw, Hex Head 1/4 x 5/8"
113	SM35H/113	Plug, Vent
114	SM35H/114	Cover, Gear Box
115	SM35H/115	Gasket, Gear Box
116	SM35CE/116	Gear, Worm
117	SM35CE/117	Key, 5mm
118	B/6005	Bearing
119	SM35H/119	C-Ring
120	SM35H/120	Seal, Oil
121	SM35H/121	Box, Gear
122	SM35H/122	Washer, Spring 5/16"
123	SM35H/123	Screw, Hex Head 5/16 x 1"
124	SM35CE/124	Wheel, Rear, Blade

Original Date:- 200999
 Version No.:- 4
 Date Modified:- 030401



PARTS DIAGRAM & LIST FOR:
12" HORIZONTAL BANDSAW

Model No: **SM35CE**

Sole UK Distributor, Sealey Group, Bury St. Edmunds, Suffolk.

☎ 01284 757500 🚚 01284 703534 **E-mail:** sales@sealey.co.uk

ITEM	PART NO.	DESCRIPTION
125	SM35H/125	Washer, 3/8"
126	SM35H/126	Screw, Hex Head 3/8 x 1"
127	SM35/B04	Blade, 4 tpi
	SM35/B08	Blade, 8 tpi
	SM35/B14	Blade, 14 tpi
	SM35/B18	Blade, 18 tpi
	SM35/B24	Blade, 24 tpi
128	SM35H/128	Cover, Blade, Back
129	SM35H/129	Cover, Wheel
130	SM35H/130	Screw, Plum
131	SM35H/131	Knob, Adjustable Guide
132	SM35H/132	Bracket, Adjustable Rear
133	B/608ZZ	Bearing
134	SM35H/134	Seat, Adjustable Blade
135	SM35H/135	Pin, Bearing
136	SM35H/136	Shaft, Eccentric
137	SM35H/137	Nut, 3/8" x 24UNF
138	SM35H/138	Washer, 3/8"
139	SM35H/139	Washer, Spring 3/8"
140	SM35CE/140	Screw, Hex Socket 5/16 x 1-1/8"
141	SM35H/141	Screw, 1/4 x 3/8"
142	SM35H/142	Plate, Vertical Cutting (Small)
143	SM35H/143	Screw, Round Head
144	SM35H/144	Screw, Hex Head 3/8 x 1-1/4"
145	SM35H/145	Support, Top
146	SM35H/146	Washer, Spring
147	SM35H/147	Nut, 3/8"
148	SM35H/148	Screw, Round Head 1/4 x 1/2"
149	SM35H/149	Washer, 1/4"
150	SM35CE/150N	Rear Blade Guard (New Type)
153	SM35CE/153	Brush
154	SM35H/154	Screw, Hex Head 5/16 x 1/2"
155	SM35CE/155N	Control Panel
155-1	SM35CE/155-1N	Motor Start/Stop Switch
155-2	SM35CE/155-2N	Pump Switch
155-3	SM35CE/155-3N	Main Power Switch
155-4	SM35CE/155-4N	Terminal Strip

ITEM	PART NO.	DESCRIPTION
155-5	SM35CE/155-5N	Fuse
155-6	SM35CE/155-6N	Fuse
155-7	SM35CE/155-7N	Transformer
155-8	SM35CE/155-8N	Magnetic Switch
155-9	SM35CE/155-9N	Overload Relay
155-10	SM35CE/155-10N	Insulation plate
155-11	SM35CE/155-11N	Support Plate
155-12	SM35CE/155-12N	Hex Head Screw
155-13	SM35CE/155-13N	Emergency Stop Switch
156	SM35CE/156	Hose, Plastic Flexible
157	SM35H/157	Screw, Set 1/4 x 1/4"
158	SM35CE/158	Support, Plastic Hose
159	SM35CE/159	Valve
160	SM35H/160	Screw, R'nd Hd 3/16 x 3/8"
161	SM35H/161	Screw, Hex Socket 5/16 x 1-1/4"
162	SM35H/162	Switch, Blade Guard Safety
163	SM35H/163	Bracket, Adjustable, Front
164	SM35CE/164N	Blade Guard
165	SM35H/165	Screw, Hex Head 1/4 x 1/2"
166	SM35H/166	Plate, Sliding Guide
167	SM35H/167	Screw, Set 5/16 x 3/4"
168	SM35H/168	Screw, Hex Head
169	SM35H/169	Block, Sliding, Blade Tension
170	SM35H/170	Screw, Hex Hed 1/4 x 1/2"
171	SM35H/171	Block, Sliding Draw
172	SM35H/172	Bracket
173	SM35H/173	Bushing, Bearing
174	B/6203ZZ	Bearing
175	SM35H/175	Wheel, Blade, Front
176	SM35H/176	Washer, 5/16"
177	SM35H/177	Screw, Hex Head 5/16 x 1"
178	SM35H/178	Screw, Round Head 1/4 x 1/2"
179	SM35H/179	Washer, 1/4"
180	SM35H/180	Washer, 3/8"
181	SM35H/181	Handle, Adjustable Blade
182	SM35H/182	Bracket, Limit Switch
183	SM35CE/183	V-Belt

ITEM	PART NO.	DESCRIPTION
184	SM35H/184	Pulley, Worm Drive
185	SM35H/185	Pulley, Motor
186	SM35H/186	Screw, Set 5/16 x 3/8"
187	SM35H/187	Screw, Hex Head 1/4 x 3/8"
188	SM35H/188	Washer, 1/4"
189	SM35H/189	Cover, Pulley
190	SM35H/190	Screw, Plum
191	SM35H/191	Key, 5mm
192	SM35H/192	Motor
193	SM35H/193	Screw, Hex Head 5/16 x 1-1/4"
194	SM35H/194	Plate, Motor Mount
195	SM35H/195	Washer, 5/16"
196	SM35H/196	Washer, Spring 5/16"
197	SM35H/197	Nut, 5/16"
198	SM35H/198	C-Ring, S-17
199	B/6003	Bearing
200	SM35H/200	C-Ring, R-35
201	SM35H/201	Seal, Oil
202	SM35H/202	Bushing, Bearing
203	SM35H/203	Shaft, Worm
204	SM35H/204	Screw, Hex Head 1/4 x 1/2"
205	SM35H/205	Washer, 1/4"
206	SM35H/206	Plate, Support
207	SM35CE/207	Limit Switch Rack
208	SM35H/208	Plate, Stop, Limit Switch
209	SM35H/209	Screw, Round Head
210	SM35H/210	Screw, Round Head
211	SM35CE/211	Plate, Blade Guard
212	SM35CE/212	Screw, Round Head
213	SM35CE/213	Nut
214	SM35CE/214	Screw
215	SM35CE/215	Washer
216	SM35CE/216N	Support Plate
217	SM35CE/217	Screw

Original Date:- 200999
 Version No.:- 4
 Date Modified:- 030401