



10PC GARAGE STORAGE SYSTEM

MODEL NO: **APMSHFP SERIES**

Thank you for purchasing a Sealey product. Manufactured to a high standard, this product will, if used according to these instructions, and properly maintained, give you years of trouble free performance.

IMPORTANT: PLEASE READ THESE INSTRUCTIONS CAREFULLY. NOTE THE SAFE OPERATIONAL REQUIREMENTS, WARNINGS & CAUTIONS. USE THE PRODUCT CORRECTLY AND WITH CARE FOR THE PURPOSE FOR WHICH IT IS INTENDED. FAILURE TO DO SO MAY CAUSE DAMAGE AND/OR PERSONAL INJURY AND WILL INVALIDATE THE WARRANTY. KEEP THESE INSTRUCTIONS SAFE FOR FUTURE USE.



Refer to instruction manual



Wear protective gloves

1. SAFETY

- WARNING!** Ensure Health & Safety, local authority, and general workshop practice regulations are adhered to when using this storage system.
- ✓ Locate in a suitable work area.
- ✓ Keep the work area clean, uncluttered and ensure there is adequate lighting.
- WARNING!** Use storage on level and solid ground, preferably concrete.
- ✓ Keep the storage system clean and tidy in accordance with good workshop practice.
- ✓ Keep children and unauthorised persons away from the work area.
- ✗ **DO NOT** use the storage system for any purpose other than that for which it is designed.
- ✗ **DO NOT** use the storage system outdoors.
- ✗ **DO NOT** place the storage system in a damp or wet location or an area where there is condensation.
- ✗ **DO NOT** clean the storage system with any solvents which may damage the surfaces or the protective coating.
- ✗ **DO NOT** move the storage system when there are items placed inside.
- ✗ **DO NOT** step on the shelves.
- ✗ **DO NOT** overload the storage system.

2. INTRODUCTION

Can be free standing or fixed to the wall. All ten units supplied on a single pallet. Hinged flat pack design makes this storage system easy and quick to assemble. Base units fitted with stylish black MDF worktops and adjustable feet. Fitted with ball bearing drawer runners and magnetic door latches. Pegboard design backing panels for additional storage. Extra units available to extend the storage system if required. Some simple assembly required.

3. SPECIFICATION

- Model no:****APMS10HFP**
Garage storage system 10pc
- Overall size: 3100 x 460 x 2080mm
- Inner drawer dimensions: 670 x 398 x 122mm
- Model no:****APMS2HFP**
Modular wall and base cabinet
- Model no:****APMS2HFPD**
Modular wall and base cabinet with drawer
- Model no:****APMS2HFPS**
Modular stacking cabinet

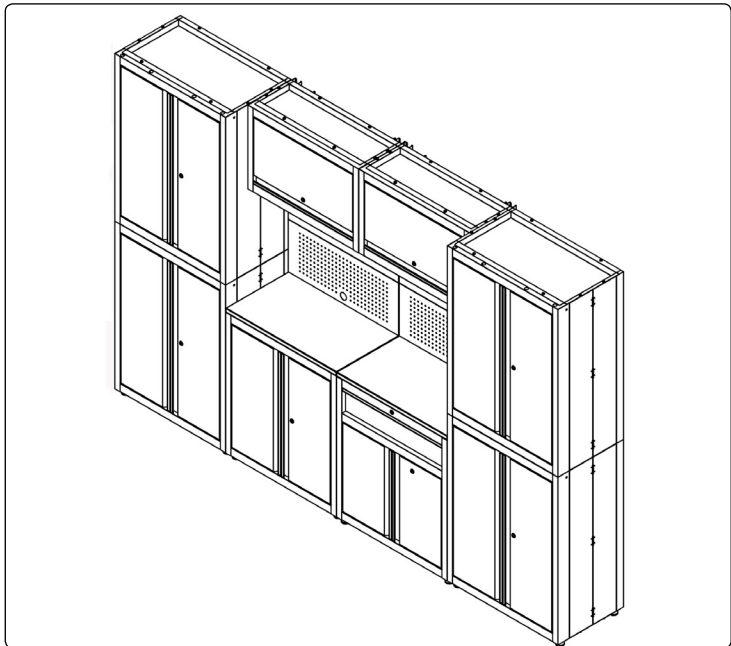

4. ASSEMBLY

1 DOOR WALL CABINET

STEP 1: Carefully separate the front and back panels, allowing the side panels to unfold completely.

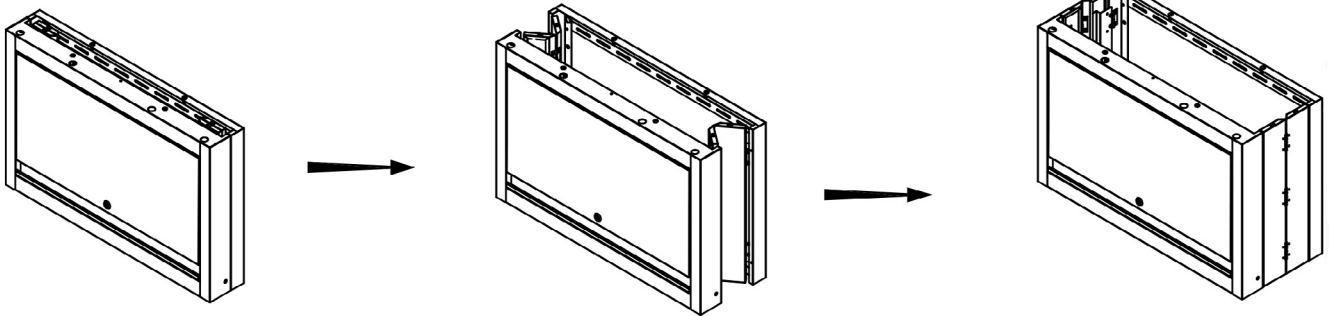

STEP 2: attach the top panel using 8x M6x16mm screws.

STEP 3: Turn the cabinet over. Attach the bottom panel using 11x M6x16mm screws.

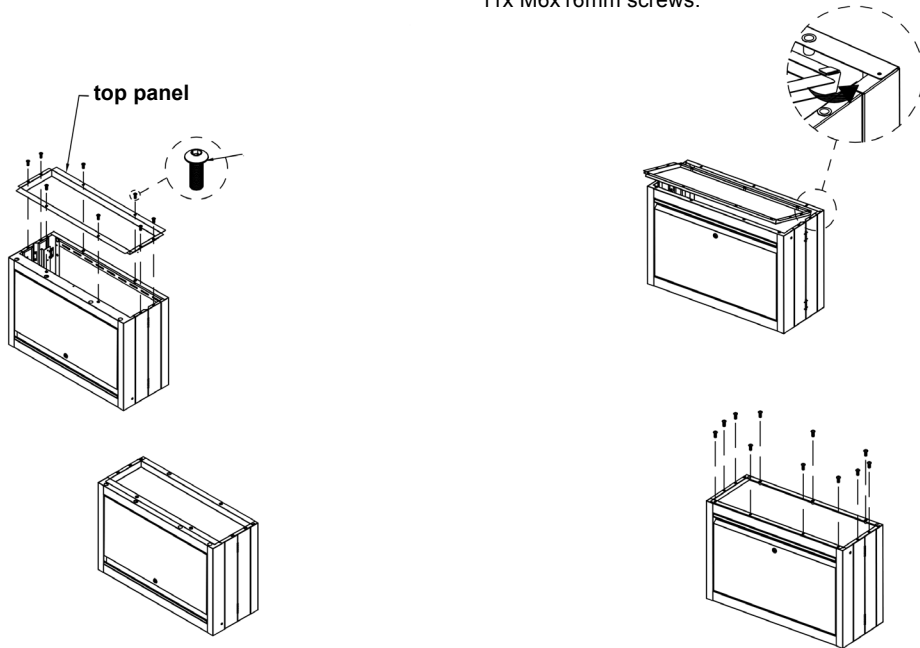

STEP 4: Insert 4 shelf supports inside the cabinet at the desired height. Place the shelf on the shelf supports.

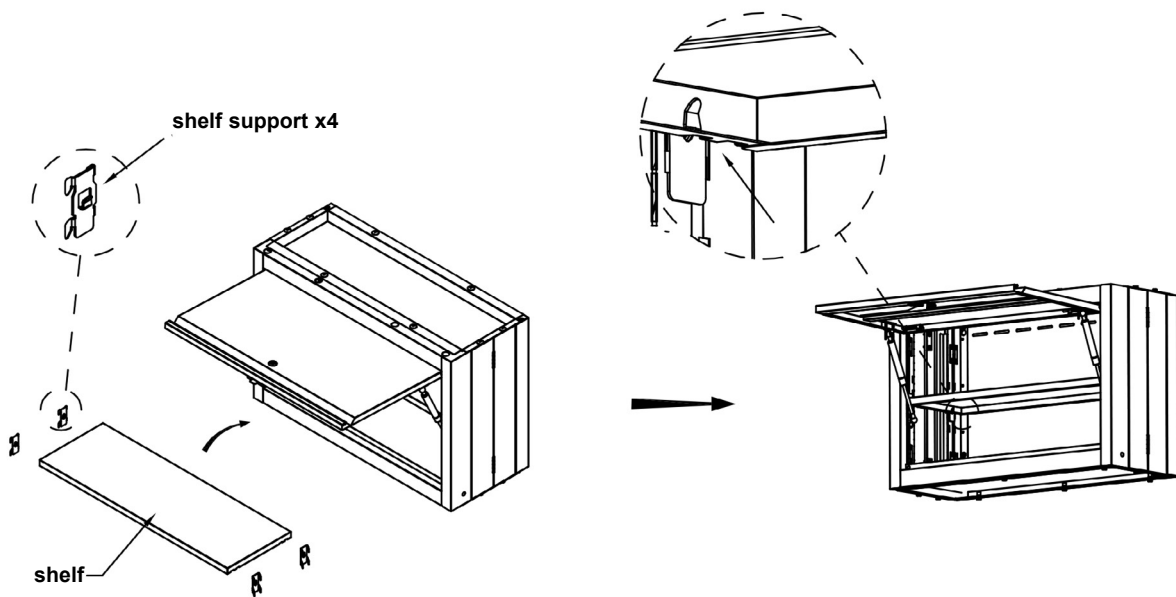

2 DOOR BASE CABINET WITH WORK TOP

STEP 1: Carefully separate the front and back panels, allowing the side panels to unfold completely.

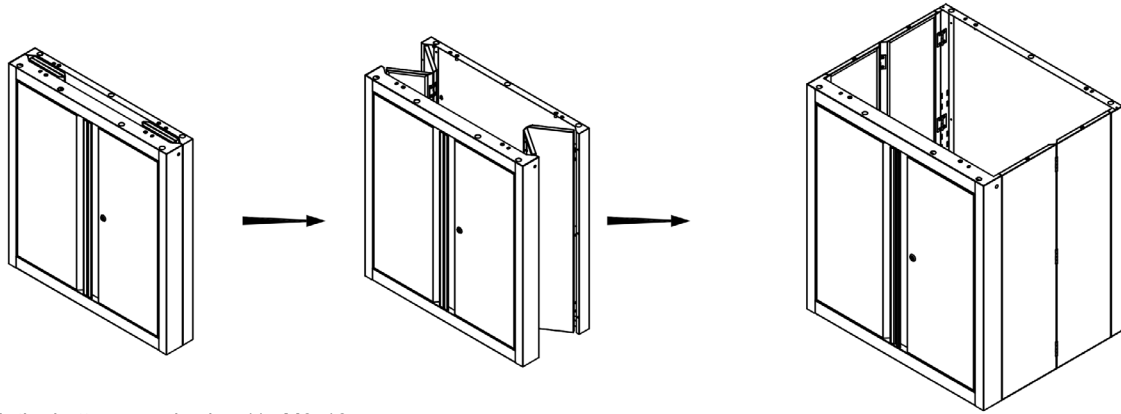

STEP 2: Attach the bottom panel using 11x M6x16mm screws.

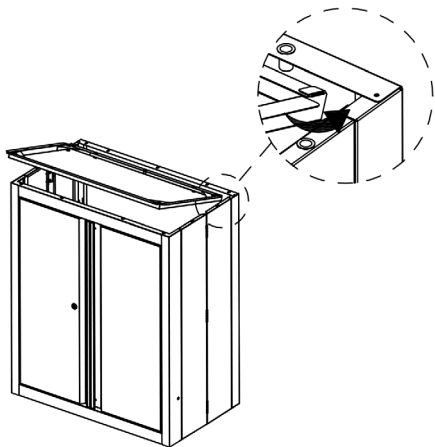

STEP 3: Screw the 4 adjustable feet into the cabinet bottom.

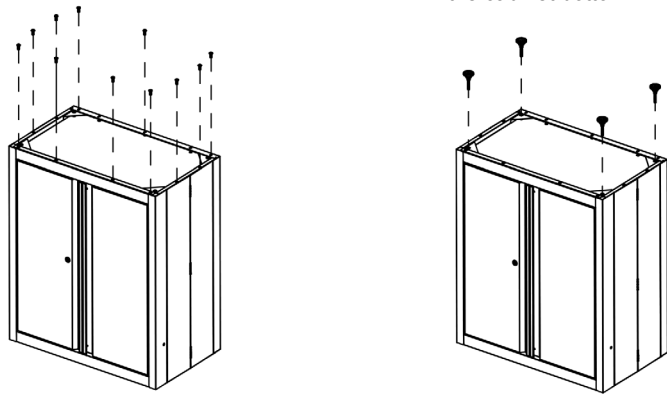

STEP 4: Attach the worktop to the cabinet using 4x M6x16mm screws.

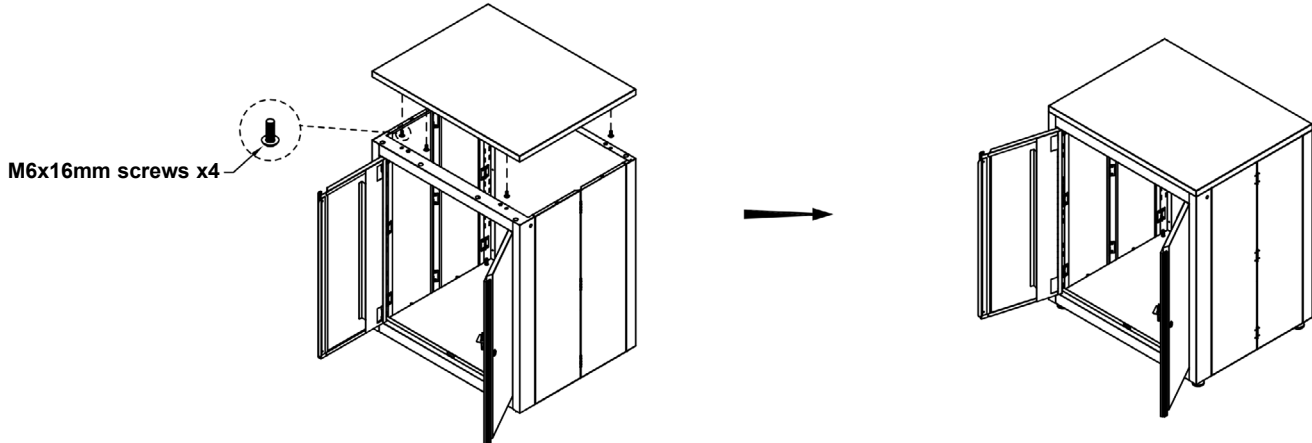

STEP 5: Insert four shelf supports inside the cabinet at the desired height. Place the shelf on the shelf supports.

NOTE: The cabinet will only lock when the shelf is placed in the centre position.

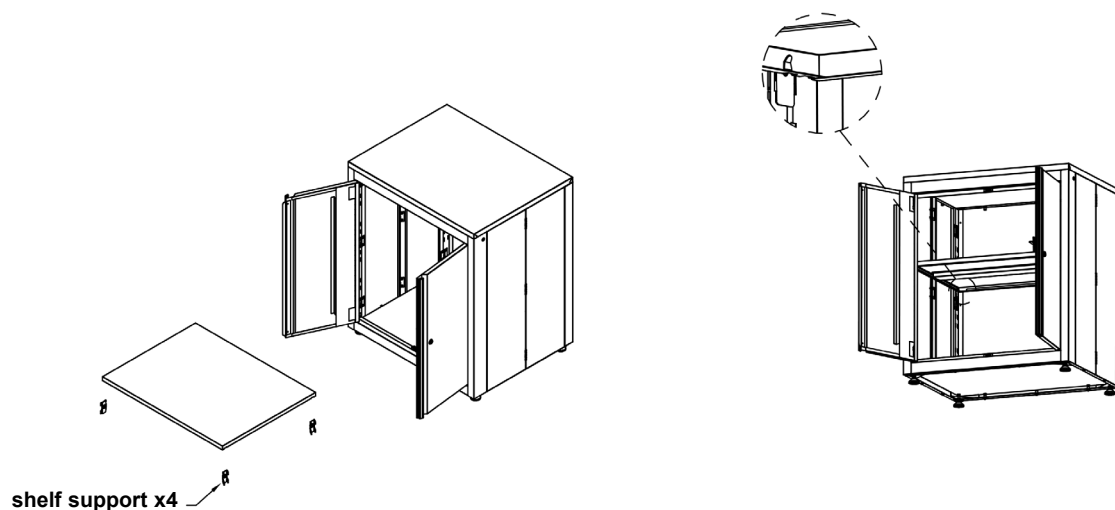

2 DOOR STACKING CABINET

STEP 1: Carefully separate the front and back panels, allowing the side panels to unfold completely.

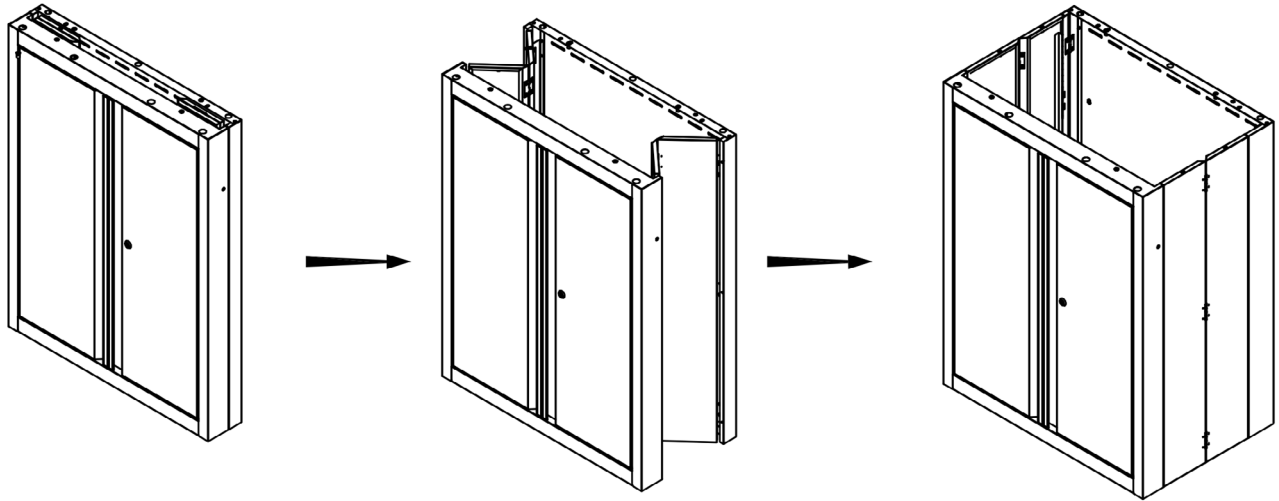

STEP 2 TOP CABINET: Attach the top panel using 8x M6x16mm hex socket head screws.

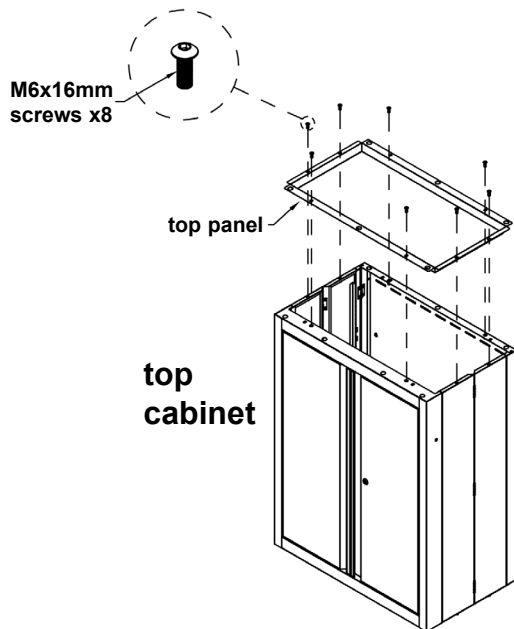

STEP 3 BOTTOM CABINET: Place the top panel on the bottom cabinet. Do not attach yet.

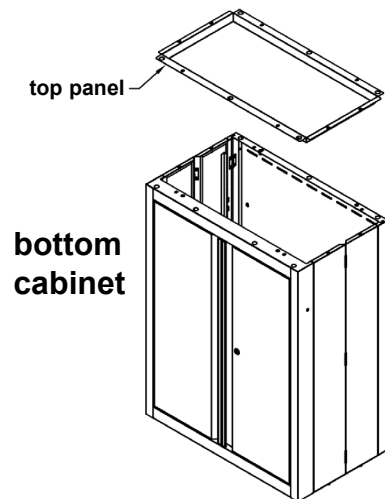

STEP 4 TOP CABINET: Turn the cabinet over. Attach the bottom panel using 7x M6x16mm screws.

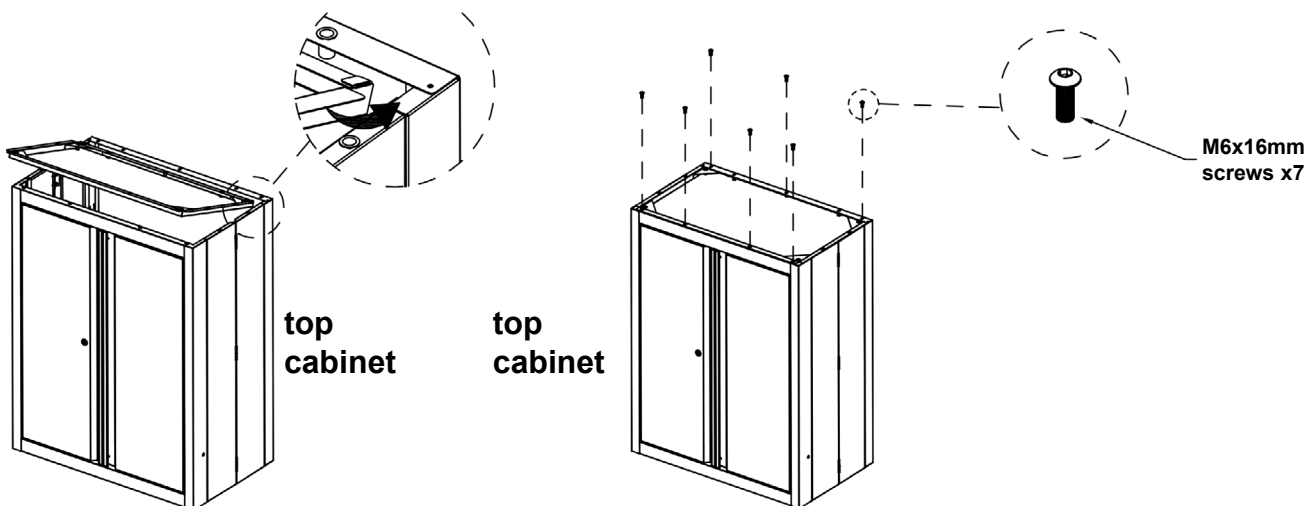

STEP 5 BOTTOM CABINET: Turn the cabinet over. Attach the bottom panel using 11x M6x16mm screws.

STEP 6 BOTTOM CABINET: Fit adjustable feet.

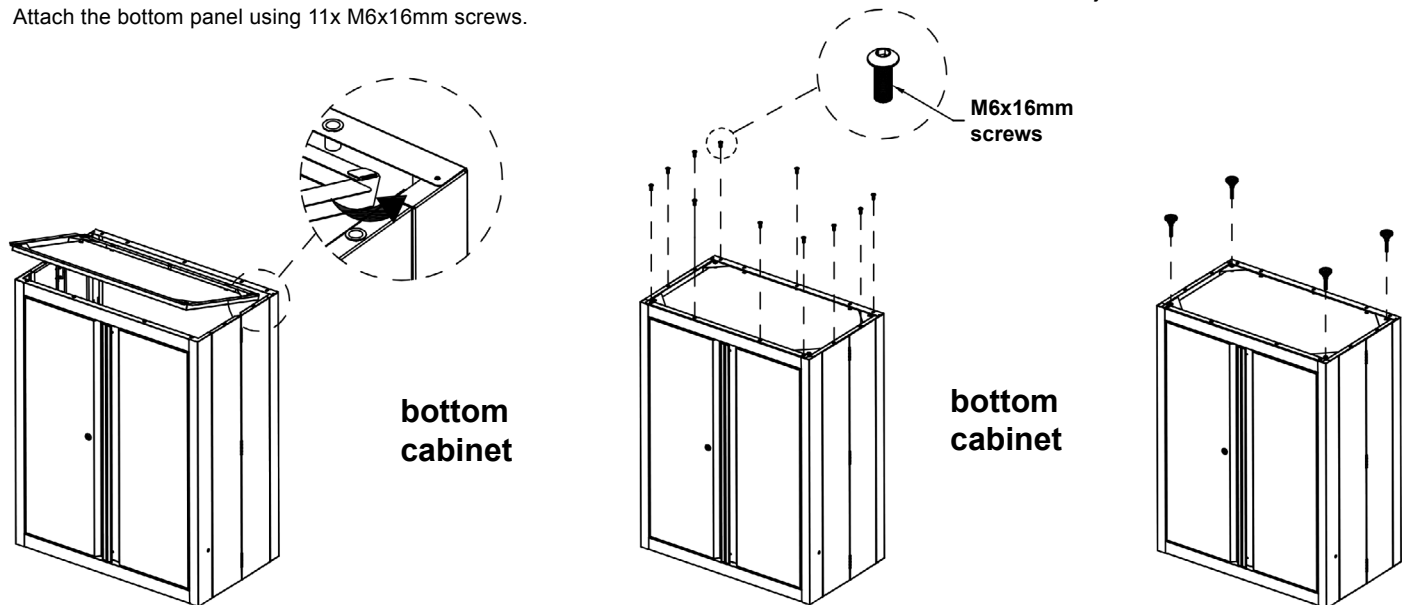

STEP 7: Place top cabinet onto bottom cabinet.

STEP 8: Connect top and bottom cabinets using M6x35mm hex flange bolts.

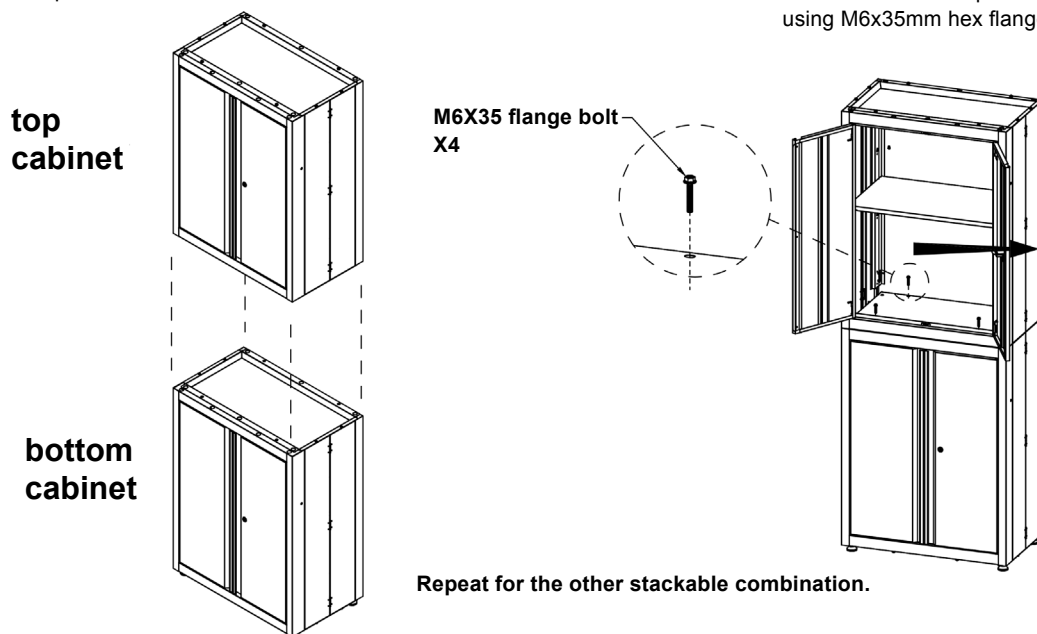

STEP 9: Insert 4x shelf supports inside the cabinet at the desired height. Place shelf on shelf supports. **NOTE:** the cabinet will only lock when the shelf is placed in the centre position.

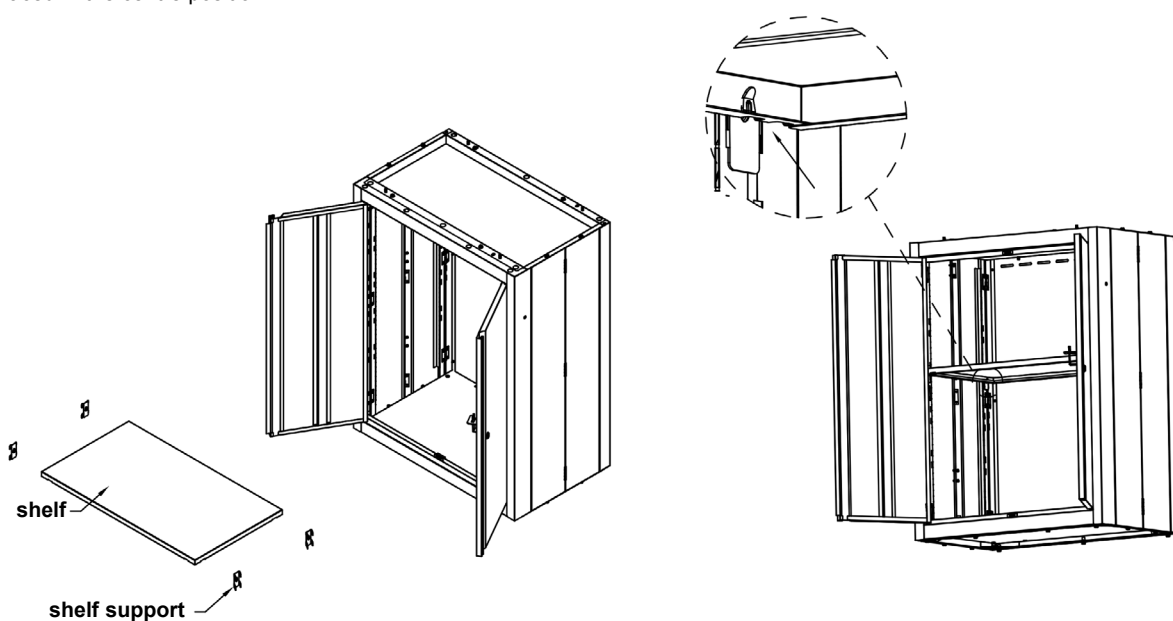

**1 DRAWER/2 DOOR CABINET WITH WORK TOP:
RAIL TYPES:**

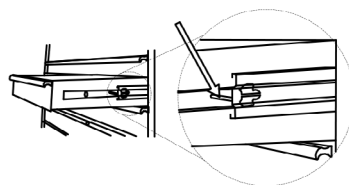
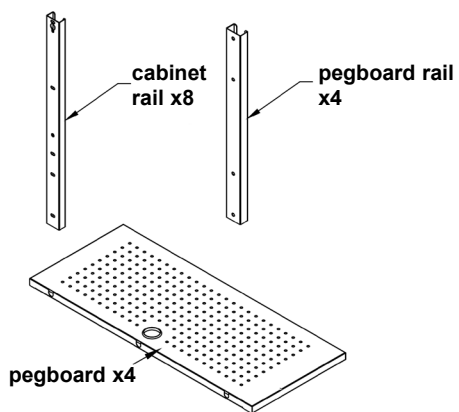

TO REMOVE DRAWERS

Pull drawer out so it's almost fully extended. Push up right hand black release lever, while pulling down left hand black release lever, pull the drawer out until it is released from the slides.

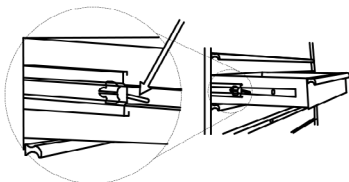

TO REPLACE DRAWERS

Extend the drawer slides. Insert the brackets on each side of the drawer into the slots in the cabinet slides, being careful to ensure that they are properly positioned. Once properly inserted, completely close the drawer to set the slides in their proper positions.

STEP 1: Fit feet.

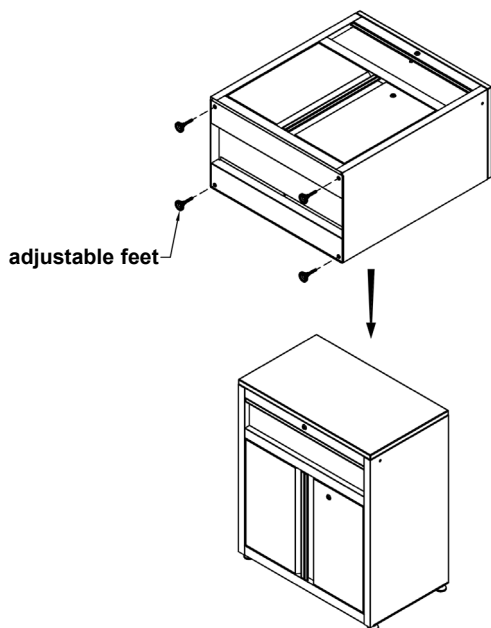

STEP 2: Attach 2x cabinet rails to the back of the base cabinet using 3x M6x16mm screws per rail.

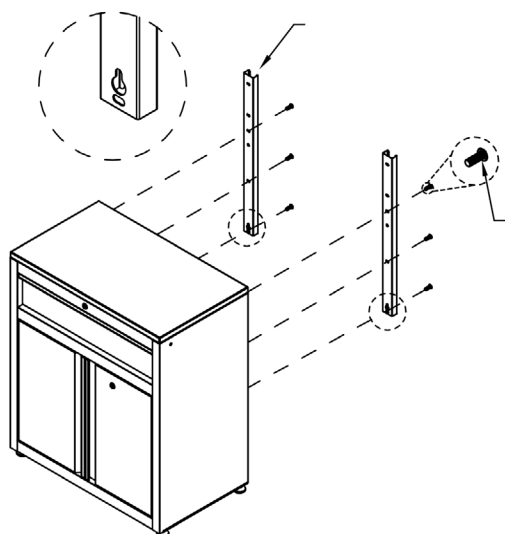

STEP 3: Slide 2x peg board rails fully onto the cabinet posts. Place one pegboard on the front, making sure the grommet hole is on the bottom. Attach using 2x M6x16mm screws per rail.

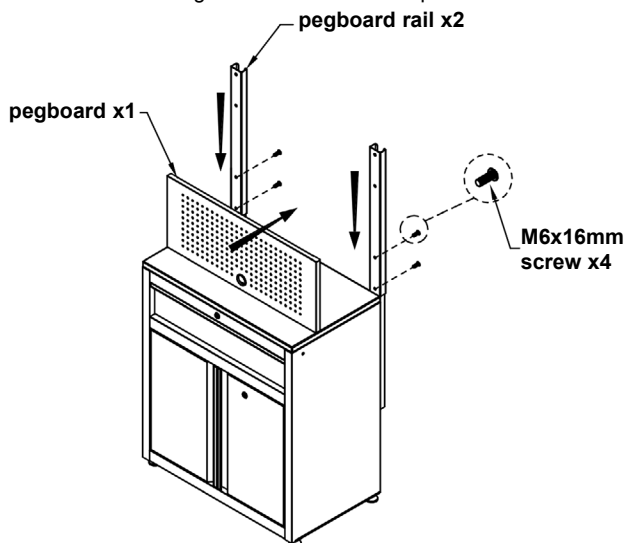

STEP 4: Slide 2 cabinet rails onto the pegboard rails. Ensure there is enough room at the top for the wall cabinet. Attach 2 cabinet rails using 2x M6x16mm screws per rail. Attach second pegboard, ensure grommet hole is at the top.

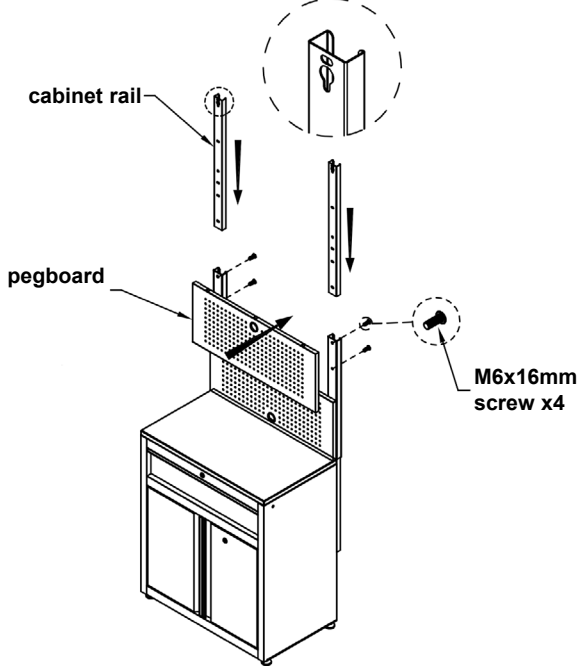

STEP 5: Screw two M6x16mm screws, into the back of the top cabinet, leaving a 0.8cm gap. Do not tighten bolts fully. Hang the wall cabinet on the top of the posts, then fully tighten the screws. Attach the bottom of the wall cabinet to the posts using another 2x M6x16mm screws.

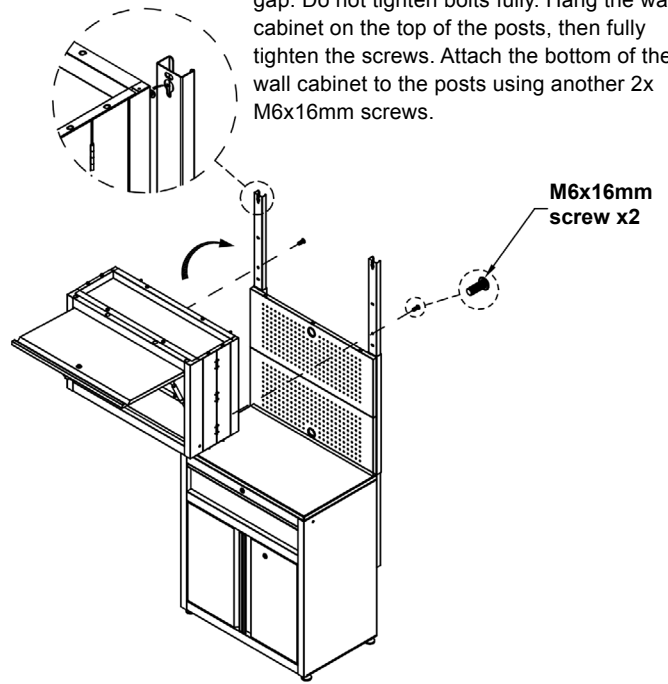

2 DOOR CABINET WITH WORKTOP:

STEP 6: Attach 2x cabinet rails to the back of the base cabinet using 3x M6x16mm screws per rail.

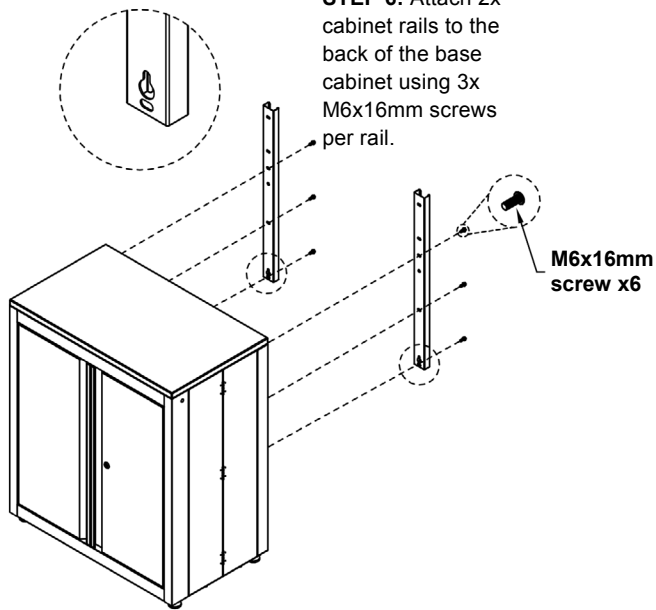

STEP 7: Slide 2 pegboard rails fully onto the cabinet rails. Place one pegboard on the front, making sure the grommet hole is on the bottom. Attach using 2x M6x16 screws per rail.

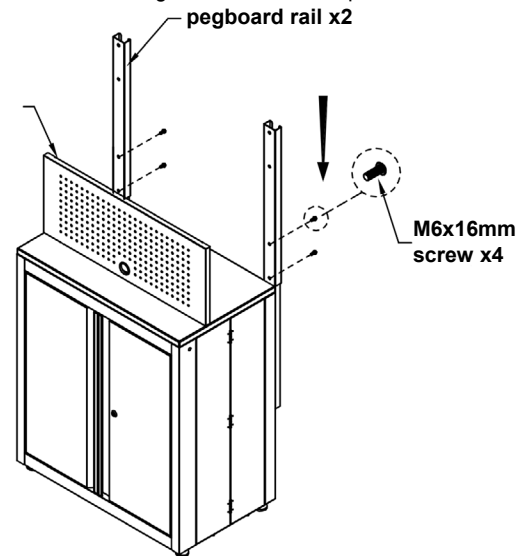

STEP 8: Slide 2 cabinet rails onto the pegboard rails. Make sure to leave enough room at the top for the wall cabinet. Place one pegboard on the front, making sure the grommet hole is on the top. Attach using 2x M6x16mm screws per rail.

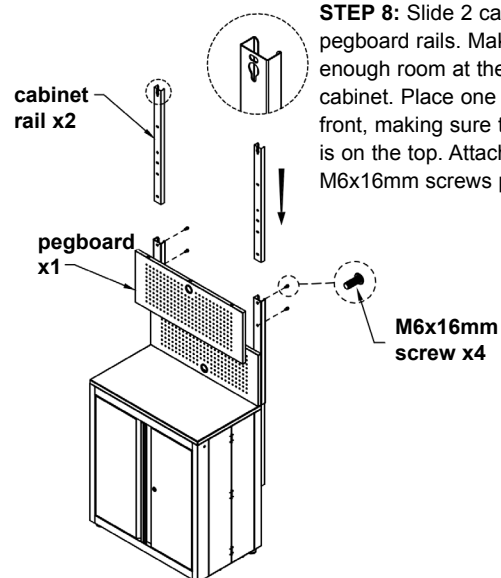

STEP 9: Screw 2x M6 x 16mm into the back of the top cabinet, leaving a 0.8cm. Do not tighten bolts fully. Hang the wall cabinet on the top of the rails, then fully tighten the screws. Attach the bottom of the wall cabinet to the rails using another two M6x 16mm screws.

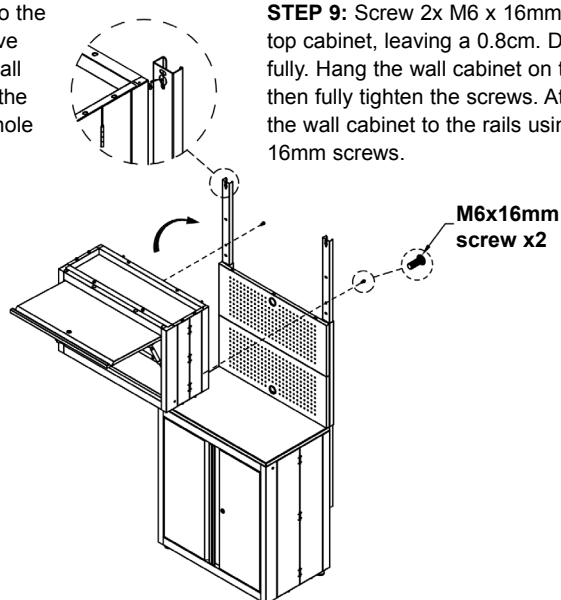

STEP 10: Push the two base cabinet/top cabinet combinations together. Insert a M6x16mm screw through the two interior end cover holes and fasten with a M6 flange nut.

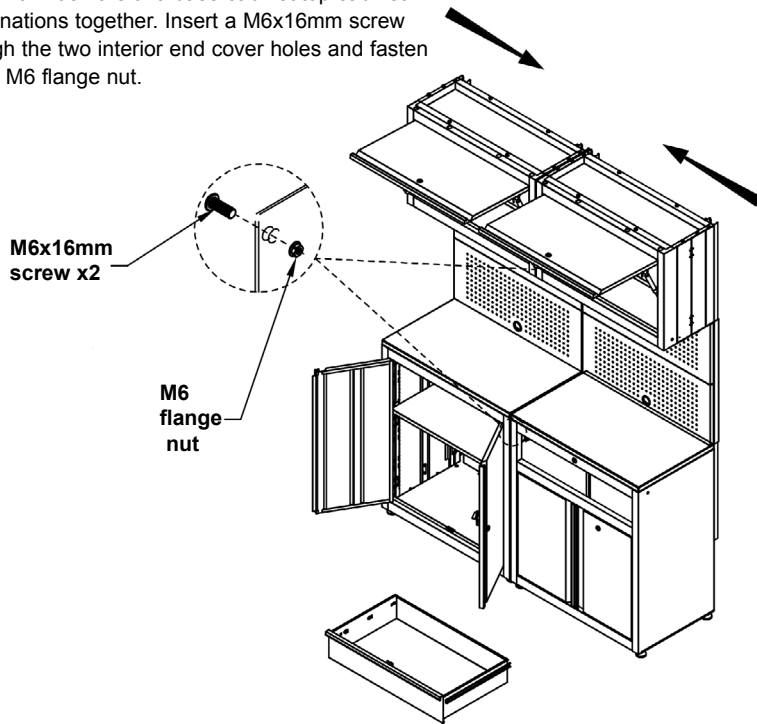

STEP 11: Push a stackable cabinet combination towards either side of the base cabinet/top cabinet combination. Insert a M6x16mm screw through the two interior end cover holes and secure with a M6 flange nut.

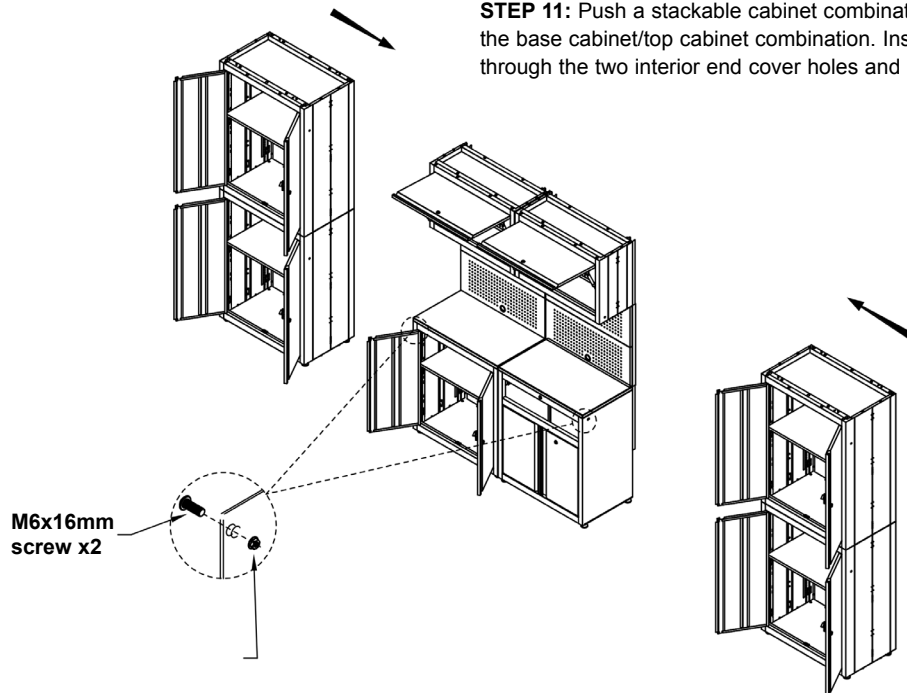

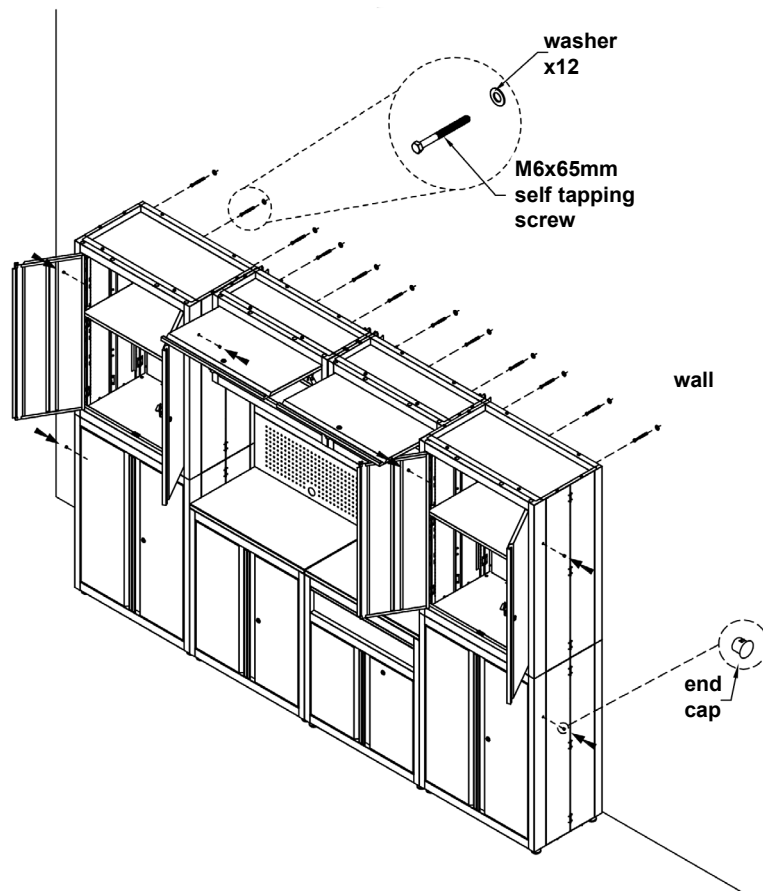

STEP 12: Attach the modular storage kit to the wall using twelve M6x65mm tapping screws and washers insert through wall studs. Insert the 6 end cups on the side panels of the cabinets.



ENVIRONMENT PROTECTION

Recycle unwanted materials instead of disposing of them as waste. All tools, accessories and packaging should be sorted, taken to a recycling centre and disposed of in a manner which is compatible with the environment. When the product becomes completely unserviceable and requires disposal, drain any fluids (if applicable) into approved containers and dispose of the product and fluids according to local regulations.

Note: It is our policy to continually improve products and as such we reserve the right to alter data, specifications and component parts without prior notice.

Important: No Liability is accepted for incorrect use of this product.

Warranty: Guarantee is 12 months from purchase date, proof of which is required for any claim.

Sealey Group, Kempson Way, Suffolk Business Park, Bury St Edmunds, Suffolk. IP32 7AR



01284 757500



01284 703534



sales@sealey.co.uk



www.sealey.co.uk