



INSTRUCTIONS FOR

SPACE WARMER® PROPANE HEATER 68,000-97,000BTU/HR

MODEL NO: **LP100.V4**

Thank you for purchasing a Sealey product. Manufactured to a high standard, this product will, if used according to these instructions, and properly maintained, give you years of trouble free performance.

IMPORTANT: PLEASE READ THESE INSTRUCTIONS CAREFULLY. NOTE THE SAFE OPERATIONAL REQUIREMENTS, WARNINGS & CAUTIONS. USE THE PRODUCT CORRECTLY AND WITH CARE FOR THE PURPOSE FOR WHICH IT IS INTENDED. FAILURE TO DO SO MAY CAUSE DAMAGE AND/OR PERSONAL INJURY AND WILL INVALIDATE THE WARRANTY. KEEP THESE INSTRUCTIONS SAFE FOR FUTURE USE.



Refer to instructions



Electrical shock hazard



Hot surfaces



Do not cover



Warning: explosive material

1. SAFETY

1.1. Electrical Safety

- WARNING!** It is the user's responsibility to check the following:
Check all electrical equipment and appliances to ensure that they are safe before using. Inspect power supply leads, plugs and all electrical connections for wear and damage. Sealey recommend that an RCD (Residual Current Device) is used with all electrical products. You may obtain an RCD by contacting your local Sealey dealer.
If used in the course of business duties, it must be maintained in a safe condition and routinely PAT (Portable Appliance Test) tested. Electrical safety information, it is important that the following information is read and understood.
- ✓ Ensure that the insulation on all cables and on the appliance is safe before connecting it to the power supply.
- ✓ regularly inspect power supply cables and plugs for wear or damage and check all connections to ensure that they are secure.
- ✓ Ensure that the voltage rating on the appliance suits the power supply to be used and that the plug is fitted with the correct fuse - see fuse rating in these instructions.
- ✗ **DO NOT** pull or carry the appliance by the power cable.
- ✗ **DO NOT** pull the plug from the socket by the cable.
- ✗ **DO NOT** use worn or damaged cables, plugs or connectors. Ensure that any faulty item is repaired or replaced immediately by a qualified electrician.
- ✓ This product is fitted with a BS1363/A 13 Amp 3 pin plug.
If the cable or plug is damaged during use, switch the electricity supply and remove from use.
Ensure that repairs are carried out by a qualified electrician.
Replace a damaged plug with a BS1363/A 13 Amp 3 pin plug. If in doubt contact a qualified electrician.
 - a) Connect the GREEN/YELLOW earth wire to the earth terminal 'E'.
 - b) Connect the BROWN live wire to the live terminal 'L'.
 - c) Connect the BLUE neutral wire to the neutral terminal 'N'.Ensure that the cable outer sheath extends inside the cable restraint and that the restraint is tight.
Sealey recommend that repairs are carried out by a qualified electrician.

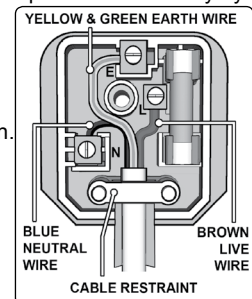

Recommended fuse rating
3 Amp

1.2. General Safety

- WARNING!** Disconnect heater from mains electrical supply and gas cylinder before servicing or performing maintenance. Replace or repair damaged parts. Use genuine parts only. Unauthorised parts may be dangerous and will invalidate the warranty.
- WARNING! NOT** to be used for the heating of habitable areas of domestic premises: for use in public buildings, refer to national regulations.
- ✓ Store gas cylinders in accordance with regulations applicable to such appliances.
- ✓ Ensure that nothing stands or passes in front of the heater. Minimum distance from the heater is 2 metres at the front, sides and rear 0.65m and 0.95m above
- ✓ Only use the propane gas pressure regulator and hose assembly supplied with the heater, without alteration.
- ✓ Ensure continuous ventilation is provided to the heater operating area. A ventilation opening must run to the outside of the premises where the heater is to be operated. The opening must be 100cm² for every kW and must also be set at an equal distance from the upper and lower parts of the heater operating area.
- WARNING!** If the heater is used for prolonged periods at maximum power, ice may form on the propane cylinder. This is due to excessive evaporation. In such a case **DO NOT** use the heater to de-ice the cylinder.
- WARNING!** If the smell of gas is present, isolate the gas cylinder immediately and investigate reason before re-connecting it.
- ✗ **DO NOT** use the heater if damaged. Take immediate action to repair or replace damaged parts. Use an authorised service agent only.
- ✗ **DO NOT** use the heater for residential use.
- ✗ **DO NOT** allow untrained persons to ignite the heater.
- ✗ **DO NOT** operate the heater without the cover.
- ✗ **DO NOT** use a naked flame to try and ignite the heater.
- ✗ **DO NOT** use the heater near flammable or explosive materials - liquids, solids or gases.
- ✗ **DO NOT** leave the heater unattended whilst in use.
- ✗ **DO NOT** obstruct the air inlet and outlet sections of the heater. Keep immediate area clean and tidy.
- ✗ **DO NOT** point the heater towards the gas cylinder.

- ✓ Keep children away from the heater.
- ✓ Keep the heater clean and in good working order.
- ✓ Ensure that the heater is correctly turned off and the gas source isolated when not in use.
- ✓ When not in use for any length of time, store heater in a safe, dry, childproof location.

NOTE: This appliance can be used by children aged from 8 years and above and persons with reduced physical, sensory or mental capabilities or lack of experience and knowledge if they have been given supervision or instruction concerning use of the appliance in a safe way and understand the hazards involved. Children shall not play with the appliance. Cleaning and user maintenance shall not be made by children without supervision

2. INTRODUCTION

Many uses have found the advantages of propane heaters far outweigh the small additional running costs. The fuel is more completely burned and does not leave an oily residue as experienced with paraffin heaters. There is no odour, except for the few seconds during start-up and the units run a little more quietly since they do not need a compressor to drive the fuel to the burner. Available with a durable paint finish or with a stainless steel body for improved corrosion resistance and stylish appearance.

Heaters are fan assisted, fitted with a piezoelectric ignition system for trouble free starting and feature a direct gas head assembly. Safety solenoids prevent the heater from leaking gas without first being electrically started. Front foot offers height adjustment allowing the heat to disperse at different angles. Supplied with an approved propane gas regulator and hose. All models are tested and certified to CE/EN standards by DVGW. Manufactured to BS EN 416.

3. SPECIFICATION

Model No.....	LP100.V4
Output	19.8 - 28.4KW
Output68,000 - 97,000Btu/hr
Airflow	400cfm
Fuel Consumption	1.5-2kg/hr
Supply	230V
Length	650mm
Width	230mm
Height	380mm
Fuel.....	Propane
Heated Area	20000ft ³
Heated Area	566mtr ³
Weight.....	7.8kg

4. OPERATION

- 4.1. **Pre Lighting**

This heater is not supplied with a gas cylinder. Use only an approved gas cylinder.

 - 4.1.1. Fasten full gas tank and connect fitting to gas cylinder valve by turning counter-clockwise. fig.2.
 - 4.1.2. With heater gas valve knob still in OFF position turn ON the gas cylinder valve and check for leaks with soap solution.
 - 4.1.3. Inspect the heater before each use, and at least annually by a qualified service person.
- 4.2. **Igniting the Heater**
 - 4.2.1. Connect the heater to a three prong (grounded) power source. You must use a three prong (grounded) extension cable that is at least 6 feet long is of the correct rating.
 - 4.2.2. Check gas control valve is in "OFF" position. fig.4.
 - 4.2.3. Connect heater to a propane gas cylinder as in 4.1.
 - 4.2.4. Turn gas valve counter clockwise to switch on gas.
 - 4.2.5. Check for gas leaks, if found rectify.
 - 4.2.6. Push in and turn gas control knob counter clockwise to position 1. This will light the burner. If needed, keep pressing control knob until the burner lights.
 - 4.2.7. Keep the valve knob depressed for at least 30 seconds after lighting the burner. After 30 seconds, release the valve knob.
 - 4.2.8. If the burner does not stay lit, repeat the lighting procedure.
 - 4.2.9. When burner stays lit, turn gas valve knob to desired setting fig.4.
- 4.3. **Switching off the Heater**
 - 4.3.1. Turn gas valve knob clockwise to "O" (off) position fig.4.
 - 4.3.2. Turn gas supply off by turning the gas cylinder valve clockwise to close.
 - 4.3.3. Disconnect the power cable.

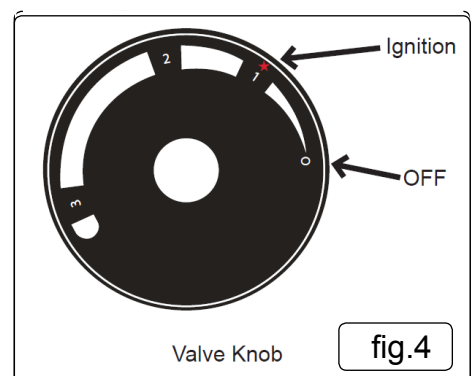
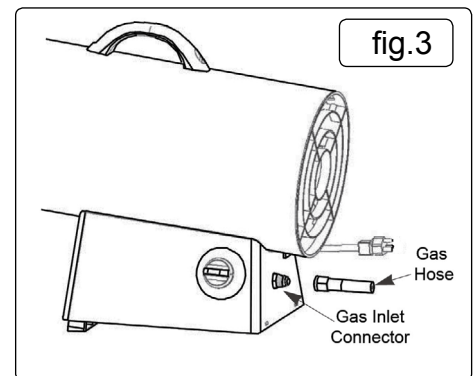
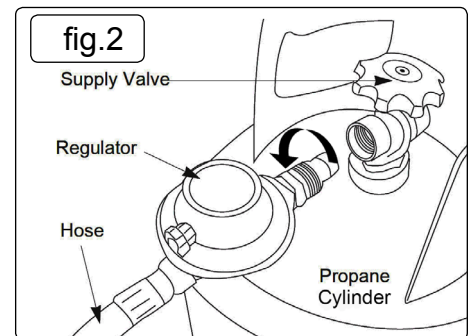
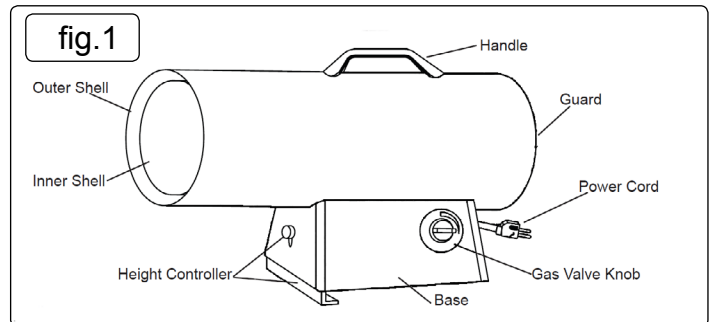

5. MAINTENANCE / STORAGE

- 5.1. Always disconnect the heater from the gas cylinder before putting the heater into storage. If for any reason the heater is to be stored indoors, the tank MUST be disconnected from the Gas cylinder, and the cylinder stored outdoors in a well-ventilated area, out of the reach of children. The plastic valve plug or valve cover supplied with the cylinder must be re-installed on the valve to protect the fitting from damage.
- 5.2. If the supply cord is damaged, it must be replaced by a special cord or assemble available from the manufacturer or its service agent. If the supply cord is damaged, it must be replaced by a special cord or assemble available from the manufacturer or its service agent.
- ▲ **DANGER!** Never store a gas cylinder inside of a building or near any other gas or oil burning appliances.
- Note:-** Installation and repair of this heater should be done by a qualified service person.
ALWAYS be sure to follow proper maintenance procedures. This should include cleaning the inside of the heater once a month and checking the spark gap at least once a heating season. Re-gap the terminals to 4mm.

6. TROUBLESHOOTING

Problem	Possible Cause	Solution
Fan does not turn when electricity is connected	No electric power to heater	Check current at outlet. If voltage is correct, inspect extension and power cords for cuts, frays or breaks.
	Blades of fan in contact with heater housing	Check housing for damage. Be sure there are no dents in the housing obstructing the fan.
	Fan blades bent	Straighten all fan blades
	Fan motor defective	Replace motor assembly
Heater will not ignite	No spark at module	Inspect module wire. Re-attach or tighten if loose. Inspect spark module and replace if necessary. Inspect all other electrical components.
	Incorrect spark gap	Set spark ignition gap to 4mm.
	Corroded electrodes	Replace spark ignition plug
Heater stops running by itself	Temperature inside heater is too high, causing thermal switch to shut down operation.	If the heater input or output is restricted, the inside temperature can become too hot. Keep the areas in front and behind clear of obstructions.
	Damaged control valve.	Replace control valve
	Dust or Debris accumulated in heater.	Clean inside of heater

Parts support is available for this product. To obtain a parts listing and/or diagram, please log on to www.sealey.co.uk, email sales@sealey.co.uk or telephone 01284 757500.



Environmental Protection

Recycle unwanted materials instead of disposing of them as waste. All tools, accessories and packaging should be sorted, taken to a recycling centre and disposed of in a manner which is compatible with the environment. When the product becomes completely unserviceable and requires disposal, drain off any fluids (if applicable) into approved containers and dispose of the product and the fluids according to local regulations.



WEEE Regulations

Dispose of this product at the end of its working life in compliance with the EU Directive on Waste Electrical and Electronic Equipment (WEEE). When the product is no longer required, it must be disposed of in an environmentally protective way. Contact your local solid waste authority for recycling information.

NOTE: It is our policy to continually improve products and as such we reserve the right to alter data, specifications and component parts without prior notice.

IMPORTANT: No liability is accepted for incorrect use of this product.

WARRANTY: Guarantee is 12 months from purchase date, proof of which will be required for any claim.



Sole UK Distributor, Sealey Group.
Kempson Way, Suffolk Business Park,
Bury St. Edmunds, Suffolk.
IP32 7AR



01284 757500



01284 703534



www.sealey.co.uk



sales@sealey.co.uk