



INSTRUCTIONS FOR:
**TOPCHEST 4 DRAWER RETRO, ROLL CAB 4 DRAWER RETRO -
 BLACK WITH RED ANODISED DRAWER PULLS**
 MODEL No's: **AP28104BR, AP28204BR**

Thank you for purchasing a Sealey product. Manufactured to a high standard, this product will, if used according to these instructions, and properly maintained, give you years of trouble free performance.

IMPORTANT: PLEASE READ THESE INSTRUCTIONS CAREFULLY. NOTE THE SAFE OPERATIONAL REQUIREMENTS, WARNINGS & CAUTIONS. USE THE PRODUCT CORRECTLY AND WITH CARE FOR THE PURPOSE FOR WHICH IT IS INTENDED. FAILURE TO DO SO MAY CAUSE DAMAGE AND/OR PERSONAL INJURY AND WILL INVALIDATE THE WARRANTY. KEEP THESE INSTRUCTIONS SAFE FOR FUTURE USE.



Refer to instruction manual



Wear protective gloves

1. SAFETY

1.1 GENERAL SAFETY

- WARNING!** Ensure Health & Safety, local authority, and general workshop practice regulations are adhered to when using this product.
- WARNING!** Use caution when handling and assembling the metal components. The metal may have sharp edges or corners, the use of protective gloves is recommended.
- DO NOT** open more than one drawer at a time.
- DO NOT** step on the drawers.
- DO NOT** let children play with the rollcab or topchest.
- Ensure all drawers are fully closed and the self locking catch is activated, before moving the toolbox.
- Secure the brakes when rollcab is in the desired position.
- Keep the work area clean, uncluttered and ensure there is adequate lighting.
- Keep the mounting frame clean and tidy in accordance with good workshop practice.
- DO NOT** use in damp work areas.
- WARNING!** The warnings, cautions and instructions referred to in this instruction manual cannot cover all possible conditions and situations that may occur. It must be understood that common sense and caution are factors which cannot be built into this product, but must be applied by the operator.

2. INTRODUCTION

Retro styled tool chests with modern day functionality. Features drawers with ball bearing slides and red anodised 'lift & latch' drawer pulls preventing inadvertent opening. Heavy duty chrome plated side handles on chest and stainless handle on rollcab for easy manoeuvrability. Topchest is further enhanced with chrome plated supports on the clam shell lid for easy opening, providing additional storage. Rollcab features stylish heavy duty castors, two with brakes. All drawers are fitted with castors and lock on one key turn.

3. SPECIFICATION

Model No:	AP28104BR	AP28204BR
Overall Dimensions (W x D x H):	700 x 450 x 495mm	730 x 460 x 825mm
Medium drawer (x 4):	570 x 400 x 60mm	n/a
Clam Shell Top:	590 x 430 x 80mm	n/a
Large drawer (x1):	n/a	570 x 400 x 105mm
Large drawer (x3):	n/a	570 x 400 x 135mm

4. ASSEMBLY

4.1. Roll Cab Handle Installation.

Position the handle over the holes in the roll cab, attach using the M6 x 12mm hex bolts and tighten securely (fig.1). Assembling the handle first will make it easier to handle the roll cab.

4.2. Castor Installation.

- 4.2.1. Lay the roll cab carefully on its back, protecting it with a soft mat placed on the floor.
- 4.2.2. Position the two rigid castors at the end opposite the handle.
- 4.2.3. Insert the M8 x 20mm hex bolts through the washers, then through the castors and into the base of the roll cab, tightening securely.
- 4.2.4. Repeat with the two swivel castors on the opposite (handle) end.

4.3. Roll Cab and Top Chest Connection.

- 4.3.1. Place the top chest onto the roll cab.
- 4.3.2. Snap the connectors into the square holes on the back of the top chest (fig.3).
- 4.3.3. Fasten the connectors with the screws provided.

Shown with
Mid-box
Model no:
AP28102BR



fig.1

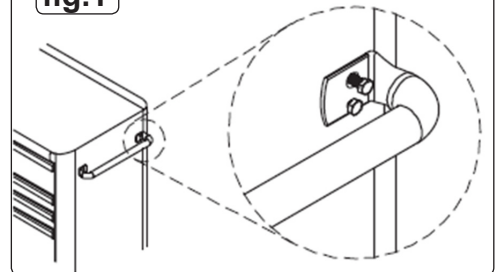

fig.2

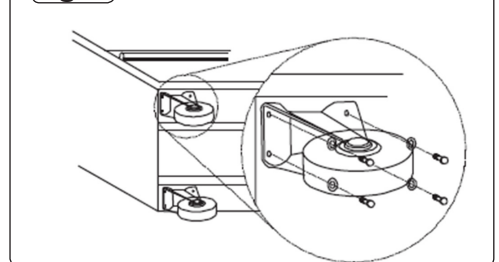
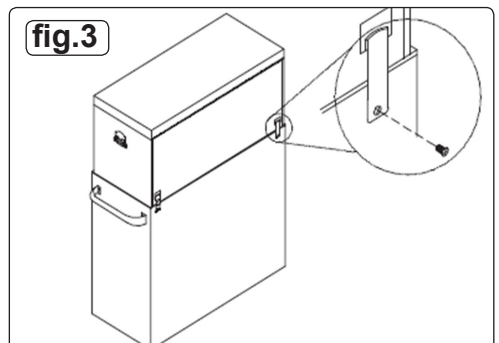

fig.3



5. OPERATION

5.1. Raise and Release Drawers.

- 5.1.1. To open: lift the drawer front whilst pulling it out (fig.4).
- 5.1.2. To close: shut the drawer firmly until the latch engages.
- 5.1.3. If the drawer does not latch, the hook (fig.4) may be misaligned or binding. Bend the hook gently until it is parallel to the drawer edge and engages when closed.

5.2. To Remove Drawers

- 5.2.1. Pull drawer out almost fully.
- 5.2.2. Locate the black locking levers (figs. 5 & 6).
- 5.2.3. Facing the drawer; lift one lever up (fig.5), and push the other lever down (fig.6).
- 5.2.4. With both levers deployed, the drawer can be pulled out from the slides.

5.3. To Replace Drawers

- 5.3.1. Extend the drawer runners from the cabinet.
- 5.3.2. Engage the slides on either side of the drawer carefully into the runners.
- 5.3.3. Push the drawer closed squarely until the drawer is closed fully, engaging the locking levers as it goes.



6. MAINTENANCE

- 6.1. Lubricate the drawer slides sparingly every six months.
- 6.2. Clean the metalwork periodically with warm water and a mild detergent.
- 6.3. Stubborn grease and oil marks can be removed by using a non-abrasive cleaner.

Environmental Protection



Recycle unwanted materials instead of disposing of them as waste. All tools, accessories and packaging should be sorted, taken to a recycling centre and disposed of in a manner which is compatible with the environment. When the product becomes completely unserviceable and requires disposal, drain off any fluids (if applicable) into approved containers and dispose of the product and the fluids according to local regulations.

NOTE: It is our policy to continually improve products and as such we reserve the right to alter data, specifications and component parts without prior notice.

IMPORTANT: No liability is accepted for incorrect use of this product.

WARRANTY: Guarantee is 12 months from purchase date, proof of which will be required for any claim.



Sole UK Distributor, Sealey Group,
Kempson Way, Suffolk Business Park,
Bury St. Edmunds, Suffolk,
IP32 7AR



01284 757500



01284 703534



www.sealey.co.uk



sales@sealey.co.uk