

DRAPER®

INSTRUCTIONS FOR Motorcycle Lift

Stock No. **37058** Part No. **MCL1**
37157 **MCL2**
37188 **MCL3**
37190 **MCL4**

IMPORTANT: PLEASE READ THESE INSTRUCTIONS CAREFULLY TO ENSURE THE SAFE AND EFFECTIVE USE OF THIS PRODUCT.



37190 MCL4 shown

DRAPER®

GENERAL INFORMATION

These instructions accompanying the product are the original instructions. This document is part of the product, keep it for the life of the product passing it on to any subsequent holder of the product. Read all these instructions before assembling, operating or maintaining this product.

This manual has been compiled by Draper Tools describing the purpose for which the product has been designed, and contains all the necessary information to ensure its correct and safe use. By following all the general safety instructions contained in this manual, it will ensure both product and operator safety, together with longer life of the product itself. All photographs and drawings in this manual are supplied by Draper Tools to help illustrate the operation of the product. Whilst every effort has been made to ensure the accuracy of information contained in this manual, the Draper Tools policy of continuous improvement determines the right to make modifications without prior warning.

1. Guarantee	1
2. Specification	2
3. Safety instructions.....	3
A. 37058 MCL1 and 37157 MCL2	
A4. Identification guide.....	4
A5. Assembly	
Levelling	5
Tie down points.....	5
Front wheel stop.....	6
Front wheel clamp.....	6
Loading ramp.....	6
Foot pedal.....	7
A6. Operation and Use	
Loading a vehicle.....	8
Raising and lowering	8
B. 37188 MCL3	
B4. Identification guide.....	9
B5. Assembly	
Levelling	10
Tie down points.....	10
Front wheel stop.....	11
Front wheel clamp.....	11
Loading ramp.....	11
Foot pedal.....	12
Air inlet.....	12
B6. Operation and Use	
Loading a vehicle.....	13
Raising and lowering	13

C. 337190 MCL4	
C4. Identification guide.....	14
C5. Assembly	
Levelling	15
Tie down points.....	15
Front wheel clamp.....	16
Safety device release trigger.....	16
Hydraulic pump assembly.....	17
Air inlet.....	17
ATV extension platform.....	18
Front wheel stop.....	18
Loading ramp.....	18
Power supply guide poles	19
C6. Operation and Use	
Loading a vehicle.....	20
Raising and lowering	20
7. Maintenance	
Cleaning and lubricating.....	21
Bleeding the hydraulic system.....	21
Decent speed.....	21
8. Disposal.....	22
Declaration of conformity.....	Enclosed

1. GUARANTEE

Draper tools have been carefully tested and inspected before shipment and are guaranteed to be free from defective materials and workmanship for a period of 12 months from the date of purchase except where tools are hired out when the guarantee period is ninety days from the date of purchase.

A proof of purchase must be provided with the tool.

Should the machine develop any fault, please return the complete tool to your nearest authorized warranty repair agent or contact Draper Tools Limited, Chandler's Ford, Eastleigh, Hampshire, SO53 1YF, England. Telephone Sales Desk: (023) 8049 4333 or Product Helpline (023) 8049 4344.

If upon inspection it is found that the fault occurring is due to defective materials or workmanship, repairs will be carried out free of charge. This guarantee does not apply to normal wear and tear, nor does it cover any damage caused by misuse, careless or unsafe handling, alterations, accident, or repairs attempted or made by any personnel other than the authorised Draper warranty repair agent.

NOTE: If the tool is found not to be within the terms of warranty, repairs and carriage charges will be quoted and made accordingly.

This guarantee applies in lieu of any other guarantee expressed or implied and variations of its terms are not authorised.

Your Draper guarantee is not effective unless you can produce upon request a dated receipt or invoice to verify your proof of purchase within the 12 month period.

Please note that this guarantee is an additional benefit and does not affect your statutory rights.



2. SPECIFICATION

The Draper Tools policy of continuous improvement determines the right to change specification without notice.

Stock no.	37058	37157	37188	37190
Part no.....	MCL1	MCL2	MCL3	MCL4
Maximum load	360kg	450kg	450kg	680kg
Unladen weight.....	104kg	138kg	141kg	260kg
Pneumatic supply:				
Maximum pressure	N/A	N/A	90PSI (6Bar)	90PSI (6Bar)
Dimensions:				
Lifting range:				
Min.....	180mm	180mm	180mm	180mm
Max.	680mm	780mm	780mm	840mm
Working height:				
Min.....	420mm	540mm	540mm	600mm
Mid.....	N/A	N/A	N/A	720mm
Max.	610mm	730mm	730mm	830mm
Removable loading ramp:				
Motorcycle:				
Length.....	420mm	600mm	600mm	825mm
Width	530mm	550mm	550mm	200mm
ATV:				
Length.....	N/A	N/A	N/A	560mm
Width	N/A	N/A	N/A	1,236mm
Wheel removal access:				
Length.....	660mm	690mm	180mm	200mm
Width	215mm	245mm	815mm	885mm
Table size (excluding loading ramps):				
Length.....	1,900mm	2,200mm	2,200mm	1,900mm
Width	530mm	680mm	680mm	1,220mm
Shipping crate size:				
Length.....	1,980mm	2,275mm	2,275mm	2,200mm
Width	585mm	740mm	740mm	950mm
Depth	260mm	280mm	280mm	1,320mm
Guide poles:	N/A	N/A	N/A	1,320mm
Air supply:				2,160mm at full height
Max. pressure.....	N/A	N/A	90PSI (6Bar)	90PSI (6Bar)
Inlet thread	N/A	N/A	1/4"BSP	1/4"BSP

**TRAVELLING ON THE LOAD CARRYING DEVICE IS FORBIDDEN.
THE VEHICLE MUST BE SECURELY STRAPPED BEFORE THE PLATFORM IS RAISED.**

Scope: This hydraulic lift is designed solely for raising vehicles (motorcycles, mopeds, scooters and ATV†) totally, for the purpose of inspection or maintenance. Any other application is considered misuse!

3. SAFETY INSTRUCTIONS

⚠ WARNING! Improper use of this lift could result in serious injury or death! Read these instructions fully before use and retain them as a part of the equipment.

- When raised, ensure the safety device is engaged to prevent collapse in the event of a hydraulic failure.
- Use this lift on flat, level ground only, suitable for the fully laden weight.
- Travelling on the load carrying device is forbidden.
- The vehicle must be securely strapped before the platform is raised.
- Ensure the lift is levelled and that the castors are raised off the ground before the vehicle is loaded on.
- Make sure there is sufficient clearance above the lift to allow for the vehicle.
- Inspect the lift before each use for signs of damage or wear and tear.
- Never use the lift if any part is damaged, missing or defective. Have the part replaced immediately, using only genuine parts supplied by the manufacturer.
- Never transport the lift when loaded.
- Ensure the vehicle to be loaded is suitable for the lift e.g. wheel base and kerb weight.
- Never exceed the rated capacity of the lift.
- Ensure the vehicle is loaded centrally to prevent the lift tipping sideways.
- Bleed the hydraulics before first use.
- Ensure the working area around the lift is free from clutter and fluid (e.g. oil) to prevent trip or slip hazards.
- Ensure the working area is properly lit.
- Never place any part of your body under the lift or around the working mechanism to prevent any crushing, shearing or unpleasant severe injuries.
- This lift must be correctly maintained and repaired by a trained and qualified person.
- As with all workshop equipment and environments, children must never be allowed near for their own safety.
- Do not operate the lift if you are tired or under the influence of drugs (prescribed or otherwise).
- Do not use the lift for any other application than that described in the scope section of this manual.
- No unauthorised persons, unfamiliar with these instructions are permitted to operate this equipment.

- Clean and lubricate the lift regularly to ensure it remains in optimum working condition.
- Take care when handling the lift - 3 to 4 persons are recommended.
- When not in use lower the lift platform fully.
- **ATTENTION! KEEP FOR FUTURE REFERENCE. This document is part of the product:** keep them for the life of the product passing onto any subsequent holder of the product.
- **WARNING! Never exceed the specified maximum working pressure.** See specification for details.
- Take care when dealing with pneumatic tools as compressed air can enter the skin and is potentially fatal.
- **FAILING TO COMPLY WITH THESE INSTRUCTIONS WILL RESULT IN THE PNEUMATIC PUMP FAILING EARLY; THIS WILL NOT BE COVERED BY THE GUARANTEE.**
- To make sure enough air reaches the pump, it should be supplied using a 3/8" diameter line or greater. If you are using an air hose over 25ft. long it is advisable to increase the bore of the hose to the next larger size available.
- The operating pressure of 90psi and must be controlled via a combined pressure regulator/lubricator water separator unit† which with proper maintenance will ensure a constant supply of dry air at all times (see illustration below). Water from condensation can build up inside the compressor tank and air lines: this will cause your equipment to rust if not properly dealt with.
- †See the Draper air tool accessory range for a suitable unit.
- Always check the air line output operating pressure before connecting to the lift.

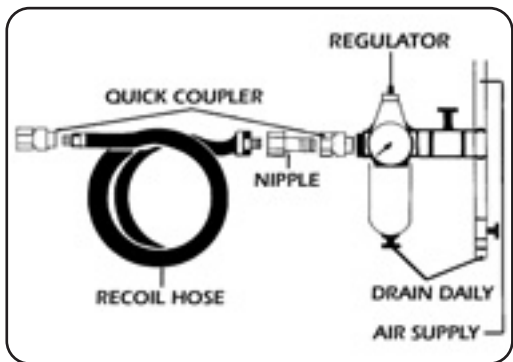

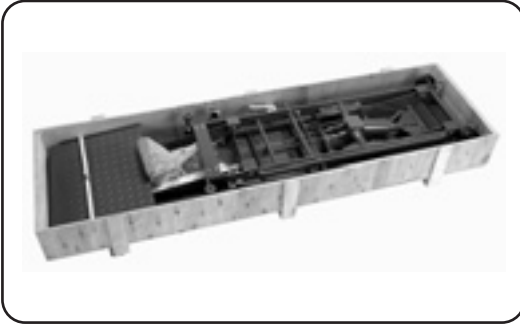

NOTE: All images in this section show motorcycle lift 37058.

⚠ WARNING! The shipping crate is heavy, splintered and during removal nails will be exposed.

Appropriate personal protective equipment must be worn (gloves, goggles and safety shoes). The lift is purposely shipped upside down for safety.

3 to 4 people are recommended to ensure safe removal and set up of the lift.

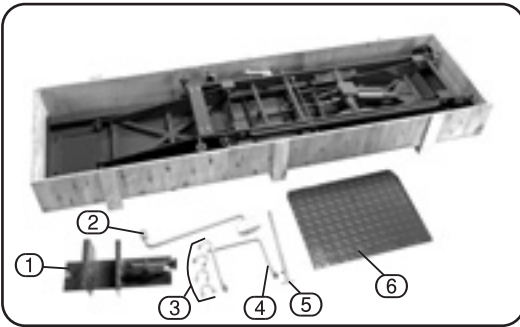

- ① Front wheel clamp.
- ② Foot pedal.
- ③ "U" bolts (tied down points).
- ④ Front wheel stop.
- ⑤ Safety device.
- ⑥ Loading ramp.

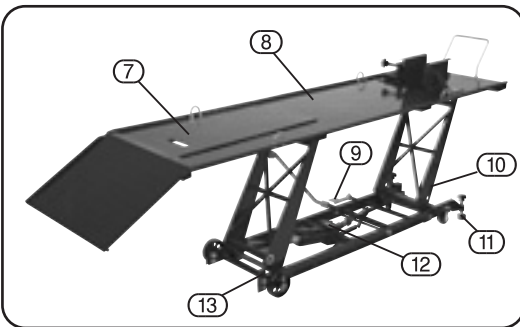

- ⑦ Wheel removal access panel.
- ⑧ Lift platform.
- ⑨ Release pedal.
- ⑩ Safety device locating point.
- ⑪ Supports.
- ⑫ Hydraulic unit.
- ⑬ Bump stops.

- **UNPACKING:** After removing the packing material, make sure the product is in perfect condition and that there are no visible damaged parts. If in doubt, do not use the product and contact the dealer from whom it was purchased.
- The packaging materials (plastic bags, polystyrene, etc.), must be disposed of in an appropriate refuse collection container. These materials must not be left within the reach of children as they are potential sources of danger.

Once the lift has been successfully removed from the shipping crate, inspected for damage and positioned in suitable location it must be levelled.

5.1 LEVELLING (Figs.1&2):

WARNING! Before any adjustments to the lift are attempted the safety device must be installed.

- i. Operate the foot pedal to raise the lifting platform.
- ii. When the platform is raised to the maximum position, install the safety device (A) in one of two available holes (B). Make certain that it is fully inserted up to the roll pin.
- iii. Press the release pedal to lower the platform down onto the safety device.

The lift is now safe to continue with the commissioning (setup) of it.

NOTE: Refer to page 8 for the detailed instructions of raising and lowering the platform.

- iv. Turn the supports (C) clockwise until both the castors (D) are completely off the ground. Then make any final adjustment to make sure the platform is level both front to back and side to side.

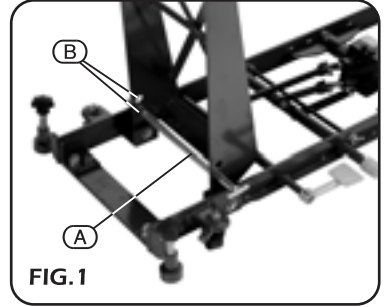

FIG. 1

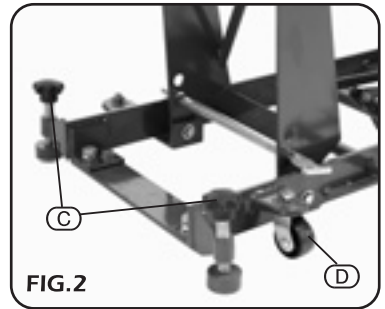

FIG. 2

The lift is supplied with 2 pairs of down points which can be installed in 3 possible locations on each side of the platform, providing versatility for different types of vehicle.

5.2 TIE DOWN POINTS (Figs.3&4):

Choose the combination of mounting points suitable to the vehicle.

- i. Pass the "U" bolts through the platform with two nuts and washers on the topside.
- ii. On the underside, place the second washer and nut.
- iii. Tighten the nuts (both top and bottom) to secure, making sure the tie down point remains level.

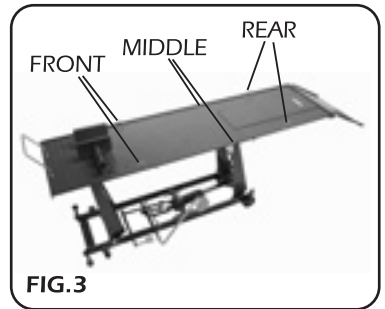

FIG. 3

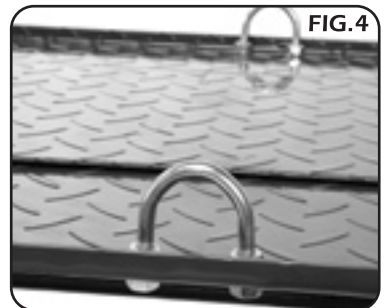
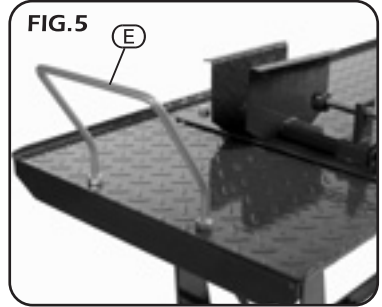

FIG. 4

5.3 FRONT WHEEL STOP (Fig.5):

To prevent the vehicle from overshooting the ramp during loading the front wheel stop (E) must be fitted.

- i. Pass the wheel stop through the platform with two nuts and washers on the topside.
- ii. On the underside, place the second washer and nut.
- iii. Tighten the buts (both top and bottom) to secure, making sure the wheel stop remains level.



5.4 FRONT WHEEL CLAMP (Figs.6&7):

To allow for different wheel bases the front wheel clamp (F) can be installed in one of three positions (G).

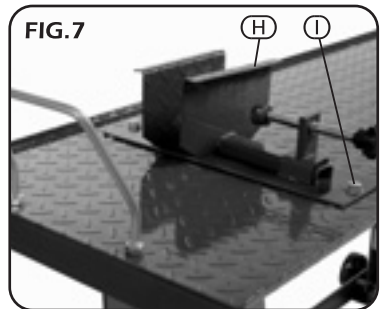
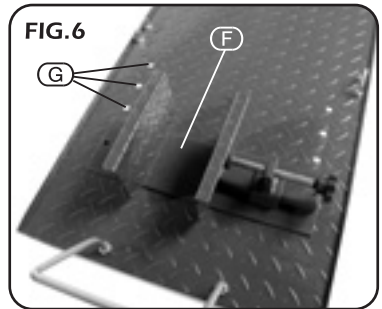
- i. Select a suitable position and align the holes.
- ii. Slide the moveable jaw (H) closed to access the bolt hole (I).
- iii. Drop them with a washer on each bolt down through the platform. Secure them with the remaining washer and nut.
- iv. Operate the foot pedal to raise the lifting platform up off of the safety device which can now be removed.
- v. Operate the release pedal once you are clear of the moving parts and it is safe to do so.

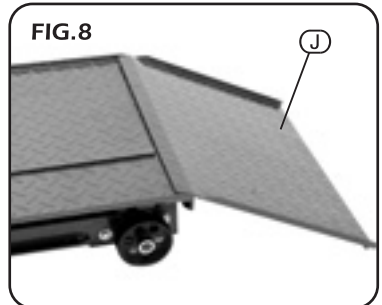

5.5 LOADING RAMP (Fig.8):

- i. Locate the pins on the underside of the loading ramp (J) with the holes in the platform.

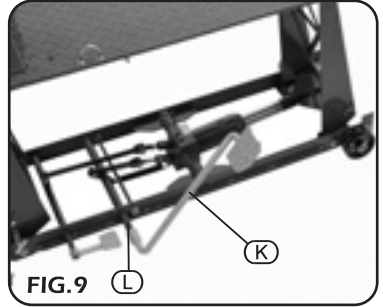

5.6 FOOT PEDAL (Fig.9):

- i. Locate the foot pedal (K) onto square drive spigot (L).



WARNING! Before first use the decent (lowering) speed must be checked and if necessary adjusted.

Refer to page 21 in the maintenance section for details.

If the vehicle is lowered too fast it may cause it to tip over.

NOTE: After transportation and before use the hydraulic system will need bleeding to remove any air build up.

6.1 LOADING A VEHICLE (Fig.10):

Assistance may be required when loading and securing a vehicle onto the lift platform.

WARNING! Never attempt to ride onto the platform.

WARNING! Never exceed the lift's capacity.

- i. Carefully push the vehicle up the loading ramp onto the platform. Make sure there is sufficient clearance between the platform and underside of the vehicle at all times.
- ii. Clamp the front wheel taking care not to damage the wheel rim.
- iii. Using ratchet straps (or other suitable strapping) secure the vehicle centrally on the platform. Take care not to cause damage to the vehicle or any of its components during this process.

NOTE: Use of centre stand (if applicable) or a paddock stand is acceptable, however a paddock stand may interfere with the removal of the access panel.

Do not use the side stand on the platform.

FIG.10



6.2 RAISING AND LOWERING (Fig.11):

No attempt should be made to lift the vehicle until it is safe and secure on the platform.

- i. To lift the platform, operate the foot pedal (M).
- ii. Insert the safety device into 1 of the 2 positions.
- iii. Lower the platform by pressing release pedal (N) until the safety device is locked in place.

Before lowering the lift platform, check nothing will become trapped or squashed.

- iv. Raise the platform enough to release and remove the safety device.
- v. Fully lower the platform by pressing foot pedal (N).

NOTE: Make sure the ramp does not catch on the floor as it lowers.

FIG.11

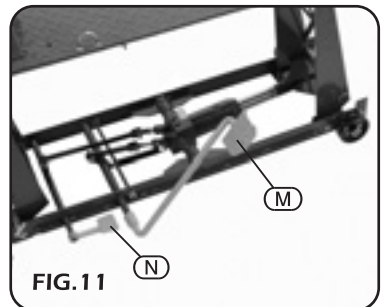

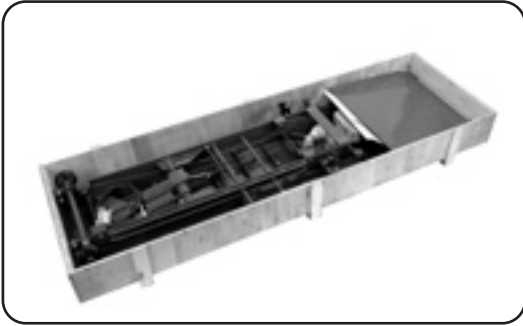

⚠ WARNING! The shipping crate is heavy, splintered and during removal nails will be exposed.

Appropriate personal protective equipment must be worn (gloves, goggles and safety shoes). The lift is purposely shipped upside down for safety.

3 to 4 people are recommended to ensure safe removal and set up of the lift.

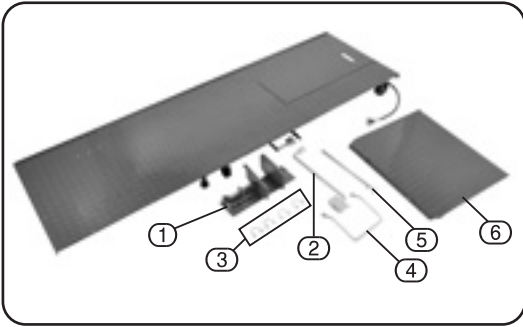

- ① Front wheel clamp.
- ② Foot pedal.
- ③ "U" bolts (tie down points).
- ④ Front wheel stop.
- ⑤ Safety device.
- ⑥ Loading ramp.

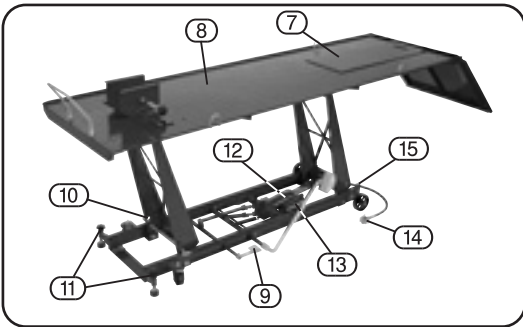

- ⑦ Wheel removal access panel.
- ⑧ Lift platform.
- ⑨ Release pedal.
- ⑩ Safety device locating point.
- ⑪ Supports.
- ⑫ Hydraulic unit.
- ⑬ Pneumatic pump.
- ⑭ Air line inlet.
- ⑮ Bump stops.

- **UNPACKING:** After removing the packing material, make sure the product is in perfect condition and that there are no visible damaged parts. If in doubt, do not use the product and contact the dealer from whom it was purchased.
- The packaging materials (plastic bags, polystyrene, etc.), must be disposed of in an appropriate refuse collection container. These materials must not be left within the reach of children as they are potential sources of danger.

Once the lift has been successfully removed from the shipping crate, inspected for damage and positioned in suitable location it must be levelled.

5.1 LEVELLING (Figs.1&2):

WARNING! Before any adjustment to the lift are attempted the safety device must be installed.

- i. Operate the foot pedal to raise the lifting platform.
- ii. When the platform is raised to the maximum position, install the safety device (A) in one of two available holes (B). Make certain that it is fully inserted up to the roll pin.
- iii. Press the release pedal to lower the platform down onto the safety device.

The lift is now safe to continue with the commissioning (setup) of it.

NOTE: Refer to page 13 for the detailed instructions of raising and lowering the platform.

- iv. Turn the supports (C) clockwise until both the castors (D) are completely, off the ground. Then make any final adjustment to make sure the platform is level both front to back and side to side.

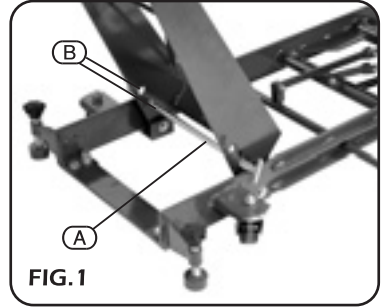

FIG. 1

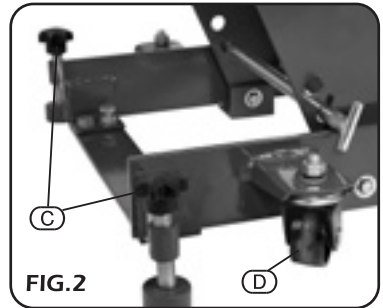

FIG. 2

The lift is supplied with 2 pairs of tie down points which can be installed in 3 possible locations on each side of the platform providing versatility for different types of vehicle.

5.2 TIE DOWN POINTS (Figs.3&4):

Choose the combination of mounting points must suitable to the vehicle..

- i. Pass the "U" bolts through the platform with two nuts and washers on the topside.
- ii. On the underside, place the second washer and nut.
- iii. Tighten the nuts (both top and bottom) to secure, making sure the tie down point remains level.

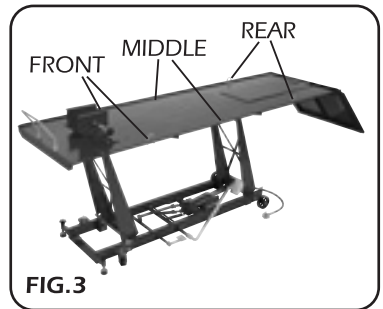

FIG. 3

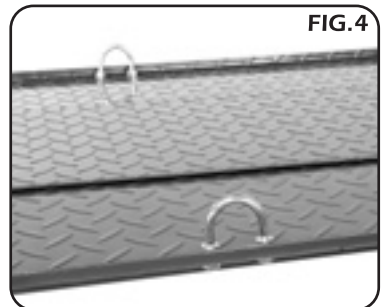
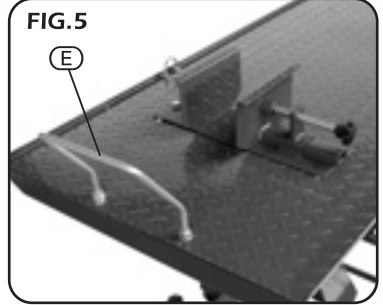

FIG. 4

5.3 FRONT WHEEL STOP (Fig.5):

To prevent the vehicle from overshooting the ramp during loading the front wheel stop (E) must be fitted.

- i. Pass the wheel stop through the platform with two nuts and washers on the topside.
- ii. On the underside, place the second washer and nut.
- iii. Tighten the butts (both top and bottom) to secure, making sure the wheel stop remains level.



5.4 FRONT WHEEL CLAMP (Figs.6&7):

To allow for different wheel bases the front wheel clamp (F) can be installed in one of three positions.

- i. Select a suitable position and align the holes.
- ii. Slide the moveable jaw (G) closed to access the bolt hole (H).
- iii. Drop them with a washer on each bolt down through the platform. Secure them with the remaining washer and nut.
- iv. Operate the foot pedal to raise the lifting platform up off of the safety device which can now be removed.
- v. Operate the release pedal once you are clear of the moving parts and it is safe to do so.

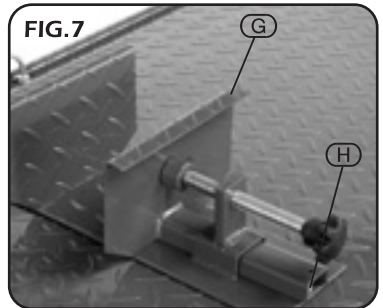
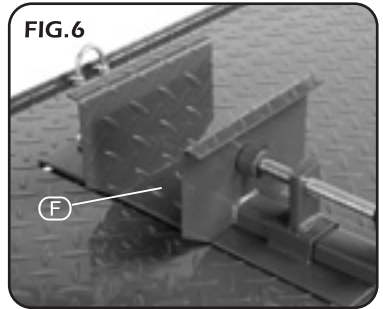

5.5 LOADING RAMP (Fig.8):

- i. Locate the pins on the underside of the loading ramp (I) with the holes in the platform.

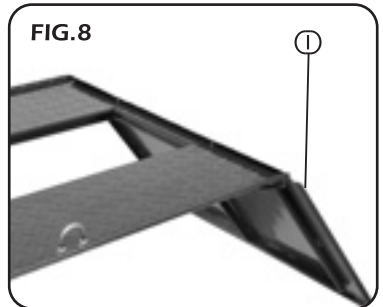

5.6 FOOT PEDAL (Fig.9):

- i. Locate the foot pedal (J) onto square drive spigot (K).

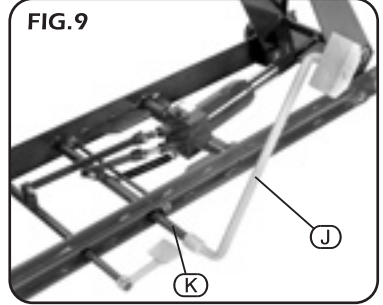
**5.7 AIR INLET (Fig.10):**

When connected to a compatible compressor, the pneumatic pump can power the hydraulics to raise the lift.

- i. Select an airline coupling (that matches your existing setup) with a 1/4" BSP male thread.
- ii. Wind a length of Draper PTFE tape (Stock No.63389) around the thread.
- iii. Screw the coupling onto the air line inlet (L).
- iv. The connection must be firm for an airtight union.

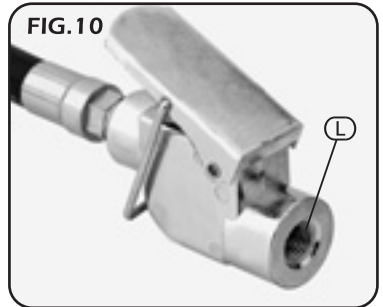

WARNING! Before first use the decent (lowering) speed must be checked and if necessary adjusted.

Refer to page 21 in the maintenance section for details.

If the vehicle is lowered too fast it may cause it to tip over.

NOTE: After transportation and before use the hydraulic system will need bleeding to remove any air build up.

6.1 LOADING A VEHICLE (Fig.11):

Assistance may be required when loading and securing a vehicle onto the lift platform.

WARNING! Never attempt to ride onto the platform.

WARNING! Never exceed the lift's capacity.

- i. Carefully push the vehicle up the loading ramp onto the platform. Make sure there is sufficient clearance between the platform and underside of the vehicle at all times.
- ii. Clamp to front wheel taking care not to damage the wheel rim.
- iii. Using ratchet straps (or other suitable strapping) secure the vehicle centrally on the platform. Take care not to cause damage to the vehicle or any of its components during this process.

NOTE: Use of centre stand (if applicable) or a paddock stand is acceptable, however a paddock stand may interfere with the removal of the access panel.

Do not use the side stand on the platform.

FIG.11



6.2 RAISING AND LOWERING (Figs.12&13):

No attempt should be made to lift the vehicle until it is safe and secure on the platform.

- i. To lift the platform, press down lever (M) to operate the pneumatic pump or operate the foot pedal (O).
- ii. Insert the safety device into 1 of the 2 positions.
- iii. Lower the platform by pressing release pedal (P) until the safety device is locked in place.

When lifting the vehicle using the pneumatic pump, the trigger can be locked "ON" by means of catch (N). When the lift platform reaches full height the pump will continue to cycle until the trigger is released.

Before lowering the lift platform, check nothing will become trapped or squashed especially the compressed air line!

- iv. Raise the platform enough to release and remove the safety device.
- v. Fully lower the platform by pressing foot pedal (P).

NOTE: Make sure the ramp does not catch on the floor as it lowers.

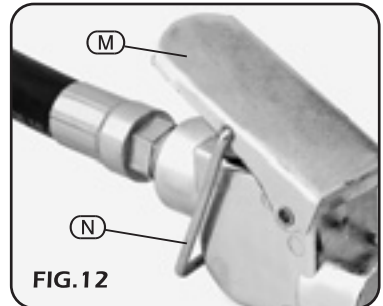

FIG.12

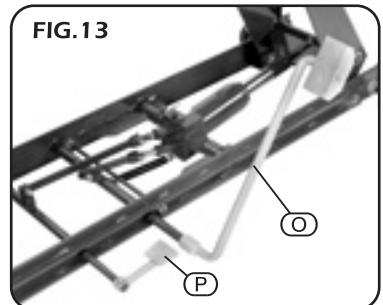
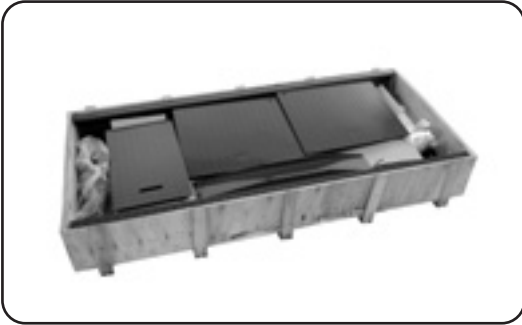

FIG.13



⚠ WARNING! The shipping crate is heavy, splintered and during removal nails will be exposed.

Appropriate personal protective equipment must be worn (gloves, goggles and safety shoes). The lift is purposely shipped upside down for safety.

3 to 4 people are recommended to ensure safe removal and set up of the lift.

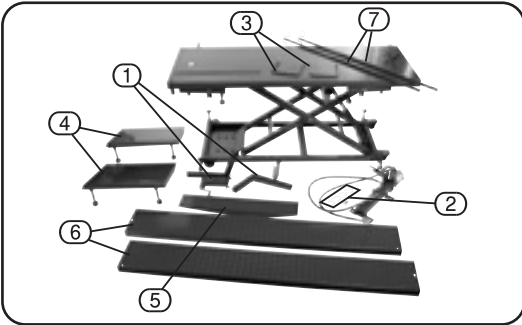

- ① Two part front wheel clamp.
- ② "U" bolts (tie down points).
- ③ Front wheel stops (ATV only).
- ④ ATV loading ramps.
- ⑤ Motorcycle loading ramp.
- ⑥ ATV extension platforms.
- ⑦ Guide poles.

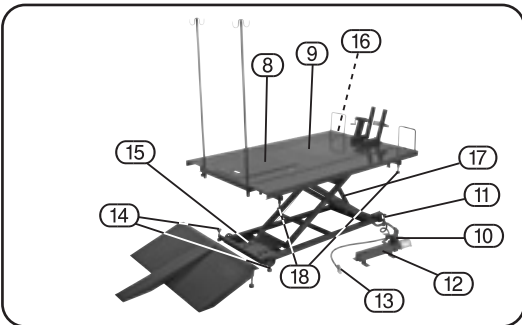

- ⑧ Wheel removal access panel.
- ⑨ Lift platform (shown with ATV platforms attached).
- ⑩ Release pedal.
- ⑪ Foot pedal.
- ⑫ Pneumatic pump.
- ⑬ Air line inlet.
- ⑭ Supports.
- ⑮ Safety device.
- ⑯ Safety device release trigger.
- ⑰ Hydraulic unit.
- ⑱ ATV supports.

- **UNPACKING:** After removing the packing material, make sure the product is in perfect condition and that there are no visible damaged parts. If in doubt, do not use the product and contact the dealer from whom it was purchased.
- The packaging materials (plastic bags, polystyrene, etc.), must be disposed of in an appropriate refuse collection container. These materials must not be left within the reach of children as they are potential sources of danger.

Once the lift has been successfully removed from the shipping crate, inspected for damage and positioned in suitable location it must be levelled.

5.1 LEVELLING (Figs.1&2):

WARNING! Before any adjustments to the lift are attempted it must be raised to at least the first safe position. This must initially be carried out manually by several people lifting the platform. When the safety device (A) is engaged correctly, the levelling can begin.

- i. Turn the supports (B) clockwise until both the casters and wheels (C) are completely off the ground.
- ii. Make any final adjustments to make sure the platform is level both front to back and side to side.

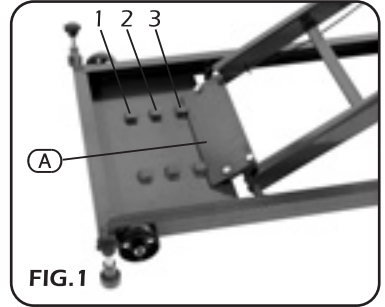

FIG. 1

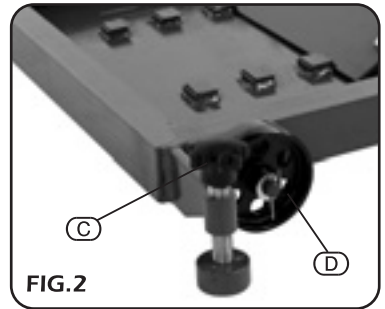

FIG. 2

5.2 TIE DOWN POINTS (Figs.3&4):

Choose the combination of mounting points must suitable to the vehicle..

- i. Pass the "U" bolts through the platform with two nuts and washers on the topside.
- ii. On the underside, place the second washer and nut.
- iii. Tighten the nuts (both top and bottom) to secure, making sure the tie down point remains level.

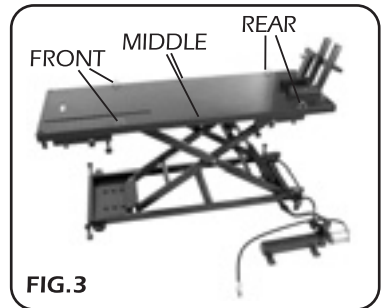

FIG. 3

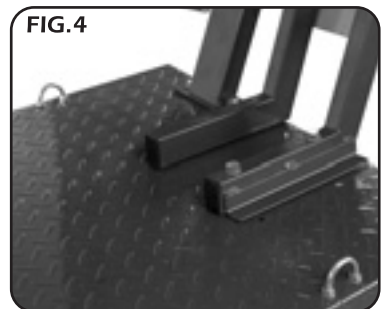

FIG. 4

5.3 FRONT WHEEL CLAMP (Figs.5&6):

To allow for different capacity bike tyres, the front wheel clamp can be installed in one of 2 positions.

- i. Position the parts of the clamp so they match the photo (Fig.5).
- ii. Align the appropriate holes in the platform.
- iii. With a washer on each bolt drop them down through the platform.
Install the remaining washer and nut on each bolt.
- iv. Secure the wheel clamp in place.

FIG.5



FIG.6



5.4 SAFETY DEVICE RELEASE TRIGGER (Figs.7&8):

- i. Place one washer next to the large nylon space and a second washer next to the nut (E).
- ii. Pass the threads through the front corner of the platform.
- iii. Place the remaining washers and bolts onto the threads and tighten.

The safety device release trigger can not be operated until the lift is raised a little.

- iv. Before first use and over time (due to stretching) the cable tension will need to be checked and adjusted loosen nut (F).
- v. With a pair of pliers pull the cable (G) tight.
- vi. When the cable is taugt, tighten nut (F) to lock in place.

FIG.7

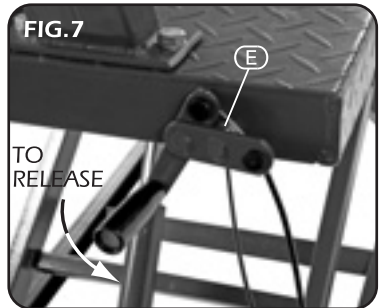
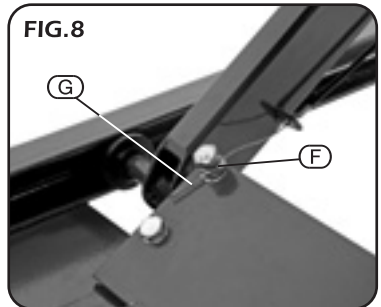

FIG.8



5.5 HYDRAULIC PUMP ASSEMBLY (Figs.9&10):

Care must be taken when installing the hydraulic pump that the high pressure hose is directed away from all moving parts.

- i. Unravel the pipe so that it lays flat.
- ii. Push the connector (hydraulic union) (H) into the connection on the hydraulic ram.
- iii. Pull the knurled nut (I) onto the pipe connection and turn it anti-clockwise until tight.

NOTE: If the lift is to remain permanently in one position we recommend the pump unit (J) be bolted to the floor with suitable fixings.

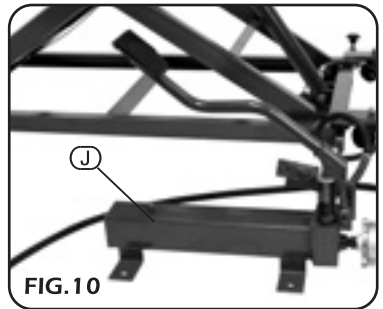
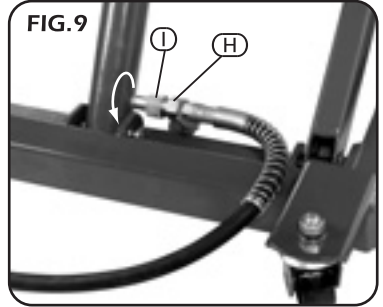

5.6 AIR INLET (Fig.11):

When connected to a compatible compressor, the pneumatic pump can power the hydraulics to raise the lift.

- i. Select an airline coupling (that matches your existing setup) with a 1/4" BSP male thread.
- ii. Wind a length of Draper PTFE tape (Stock No.63389) around the thread.
- iii. Screw the coupling onto the air line inlet (K).
- iv. The connection must be firm for an airtight union.

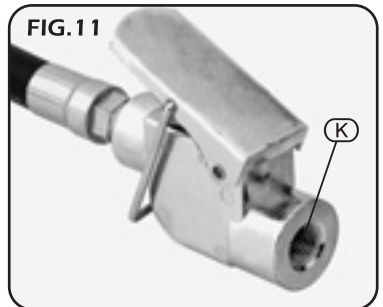

5.7 ATV EXTENSION PLATFORM (Figs.12&13):

To allow all terrain vehicles (ATVs) ride on mowers and quads to be lifted the extension platform must be fitted.

- i. Fold out the 4 arms (L) 90°.
- ii. Lift the extension platform (M) onto the arms. Align them with the front and back of the main platform
NOTE: The mounting holes (for the front wheel stops) must be at the front of the lift.
- iii. On each of the 4 arms hangs a metal plate with 2 bolts in each.
 Remove the nuts and 1 washer.
- iv. Spin the metal plate around to align it with the brackets on the underside of the extension platforms.
- v. Securely bolt the metal plate to the bracket.

ATTENTION! When the extension platforms are not in use, the bracket (O) must be removed by way of the split pin otherwise it may foul on the rear wheels when lowering the lift.

NOTE: When lowered fully the supports (M) must be adjusted to match the setup of the main supports (N) to prevent the lift tipping.

FIG. 12

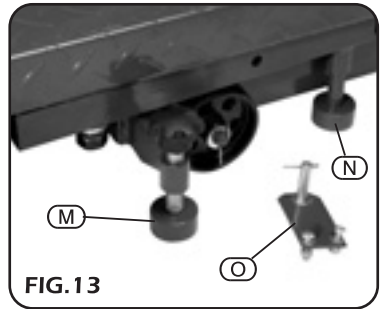
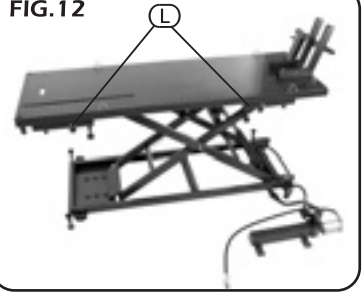

FIG. 13

5.8 FRONT WHEEL STOPS (Fig.14):

To prevent the vehicle from overshooting the ramp during loading the front wheel stops (P) must be fitted.

- i. Pass the wheel stops through the platform with two nuts and washers on the topside.
- ii. On the underside, place the second washer and nut.
- iii. Tighten the nuts (both top and bottom) to secure, making sure the wheel stops remains level.
- iv. If required for access, the front wheel clamp may be removed when the lift is in ATV mode.

FIG. 14

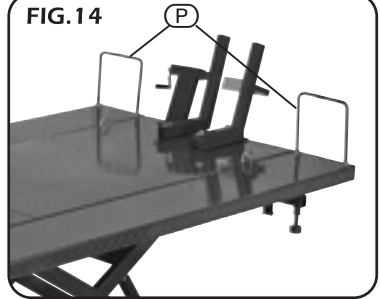

5.9 LOADING RAMPS (Fig.15):

Set up of the loading ramps should be carried out when the lift is fully lowered to avoid mis alignment.

- i. Push the 2 large ramps (Q) up to back of the platform.

NOTE: These ramps both have a mounting hole for the motorcycle ramp which must be on the inside edges.

- ii. Adjust the ramp legs so they are the same height as the platform and appear level with it.
- iii. The motorcycle ramp (R) slots into the mounting holes on the large ramps when required.

FIG. 15

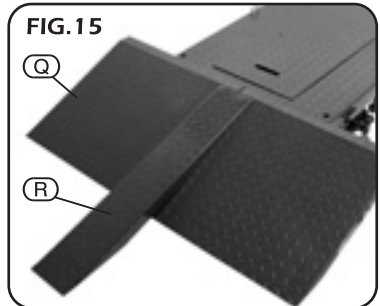

5.10 GUIDE POLES (Fig.16):

When working on any vehicle it may be necessary to trail power cables (for lighting) or air lines (for air tools) around the vehicle. To help keep work area tidy and prevent damage to the vehicle body use the guide poles (S). These can also be used to ensure the vehicle will not roll back off of the ramp during operation.

- i. Slot the poles into the holes at the back of the platform.

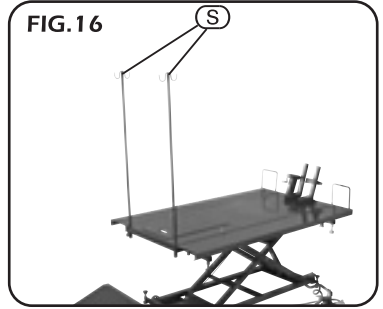

NOTE: After transportation and before use the hydraulic system will need bleeding to remove any air build up.

6.1 LOADING A VEHICLE (Fig.17):

Assistance may be required when loading and securing a vehicle onto the lift platform.

WARNING! Never attempt to ride onto the platform.

WARNING! Never exceed the lift's capacity.

- i. Carefully push the vehicle up the loading ramp onto the platform. Make sure there is sufficient clearance between the platform and underside of the vehicle at all times.
- ii. Clamp the front wheel taking care not to damage the wheel rim.
- iii. Using ratchet straps (or other suitable strapping) secure the vehicle centrally on the platform. Take care not to cause damage to the vehicle or any of its components during this process.

NOTE: Use of centre stand (if applicable) or a paddock stand is acceptable, however a paddock stand may interfere with the removal of the access panel.

Do not use the side stand in the platform.



FIG.17

6.2 RAISING AND LOWERING (Figs.18&19):

No attempt should be made to lift the vehicle until it is safe and secure on the platform.

- i. To lift the platform, press down lever (T) to operate the pneumatic pump or operate the foot pedal (V).
- ii. The safety device will engage as the platform is raised.
- iii. Lower the platform (W) to lock the safety device before use.

When lifting the vehicle using the pneumatic pump, the trigger can be locked "ON" by means of catch (U). When the lift platform reaches full height the pump will continue to cycle until the trigger is released.

Before lowering the lift platform, check nothing will become trapped or squashed.

- iv. Raise the platform enough to clear the safety device.
- v. Operate the release trigger while you fully lower the platform by pressing foot pedal (W).

NOTE: Make sure the ramp does not catch on the floor as it lowers.

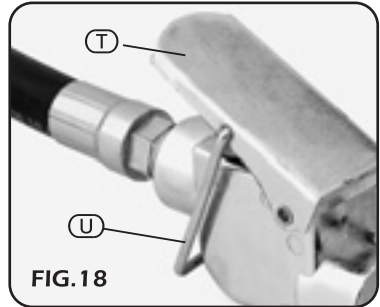

FIG.18

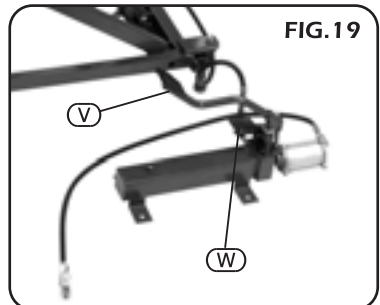

FIG.19

7. MAINTENANCE

The maintenance of these lifts must be carried out by an approved service contractor qualified to do so.

In addition, some basic day to day maintenance must be carried out to keep the lift in a safe working condition.

7.1 CLEANING AND LUBRICATING:

As the working environment for this type of product is generally dirty and dusty, it is important the lift is regularly cleaned particularly any moving parts.

Lubricate moving parts with a general purpose grease or oil as applicable.

7.2 BLEEDING THE HYDRAULIC SYSTEM (Figs.14&15):

After transportation and long periods of service, air can build up in the hydraulic system.

Failing to bleed this air, can result in oil pushing past the seals causing premature failure.

- i. Remove the inlet bung (X).

NOTE: For lift 37190 unscrew the air bleed valve (Y).

- ii. While holding down the release pedal.
- iii. Operate the foot pedal 6 to 8 times forcing any trapped air into the reservoir where is it released.

NOTE: This does not apply to lift 37190.

7.3 DECENT SPEED (Fig.16):

When unladen the lift platform should lower slowly. If incorrectly set up the platform will either collapse too fast which is dangerous or not move at all even when fully laden.

NOTE: This does not apply to lift 37190.

When adjusting the speed, remember the vehicle weight will increase it slightly.

- i. To increase the decent speed turn screw (Z) anti-clockwise. Only make slight adjustments before testing the speed. To decrease the speed turn the screw clockwise.

WARNING! Never adjust this with a vehicle loaded on the lift.

ATTENTION! Do not adjust screw (AA). This is factory set. Do not tamper.

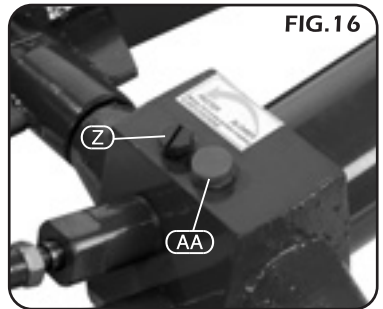
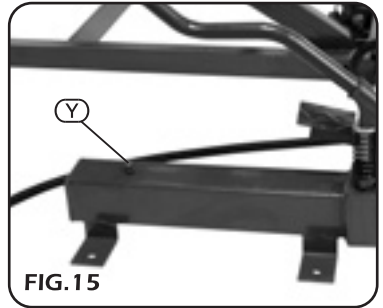
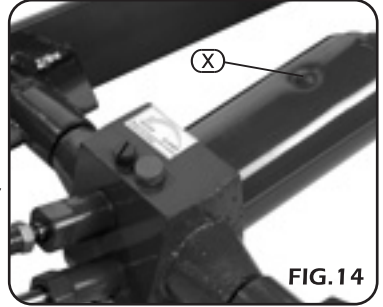

8. DISPOSAL

- At the end of the machines working life, or when it can no longer be repaired, ensure that it is disposed of according to U.K. regulations.
- Contact your local authority for details of collection schemes in your area.

In all circumstances:

- Do not dispose with domestic waste.
- Do not incinerate.
- Do not abandon in the environment.
- When decommissioning remove all subsidiary fluids for appropriate disposal.

- **DRAPER TOOLS LIMITED,**
Hursley Road, Chandler's Ford,
Eastleigh, Hampshire. SO53 1YF. U.K.

- **Helpline:** (023) 8049 4344
- **Sales Desk:** (023) 8049 4333
- **Internet:** www.draper.co.uk
- **E-mail:** sales@drapertools.com
- **Sales Fax:** (023) 8049 4209
- **General Enquiries:** (023) 8026 6355

- **Service/Warranty Repair Agent**
For aftersales servicing or warranty repairs, please
contact the Draper Tools Helpline for details of an
agent in your local area.

YOUR DRAPER STOCKIST

OAKC300710

©Published by Draper Tools Limited.

No part of this publication may be reproduced, stored in a retrieval system or transmitted in any form or by any means, electronic, mechanical photocopying, recording or otherwise without prior permission in writing from Draper Tools Ltd.